



## **Electric pedestrian stacker** **EJC B12n / 110n / 112n**

**Lift height: 2900-3373 mm / Load capacity: 1000-1200 kg**

# EJC B12n / 110n / 112n

EJC\_1n

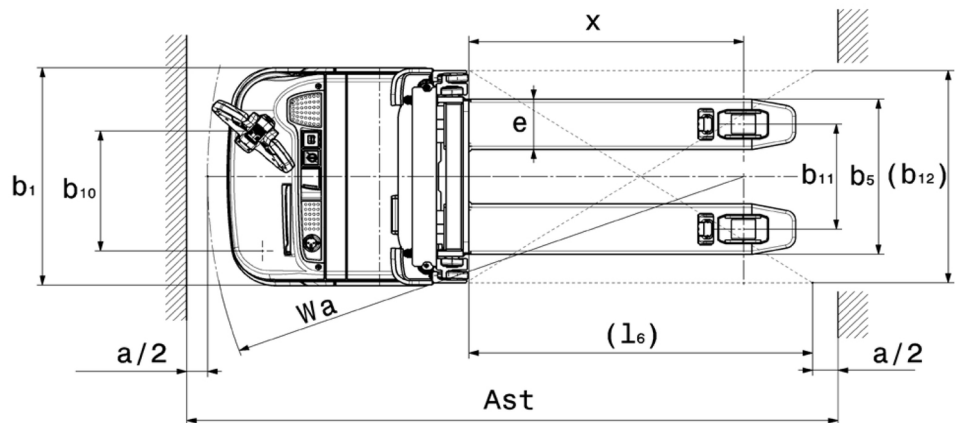
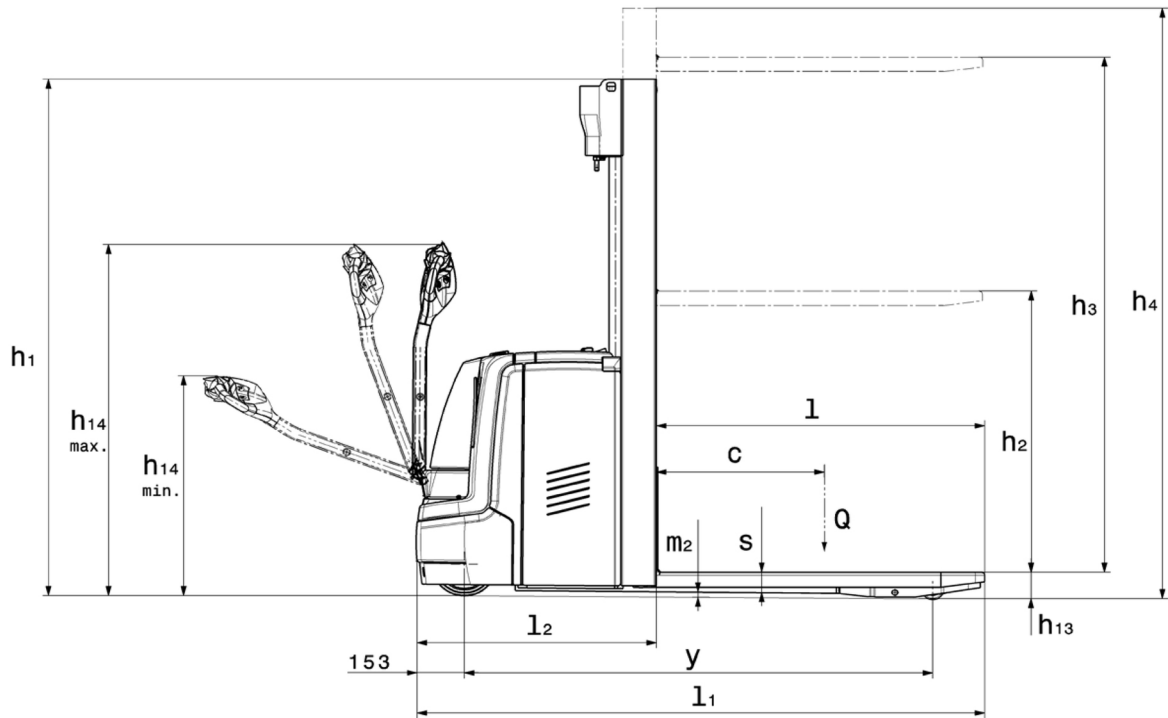

# EJC B12n / 110n / 112n

EJC\_B12

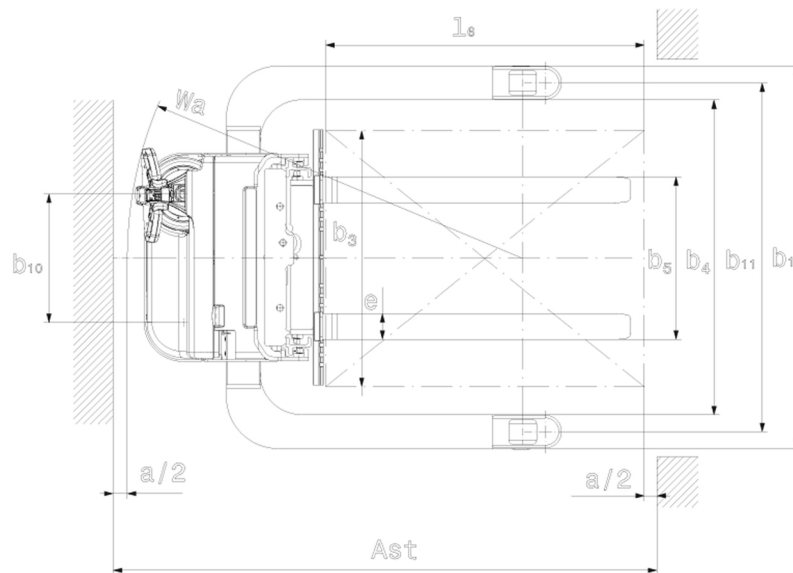
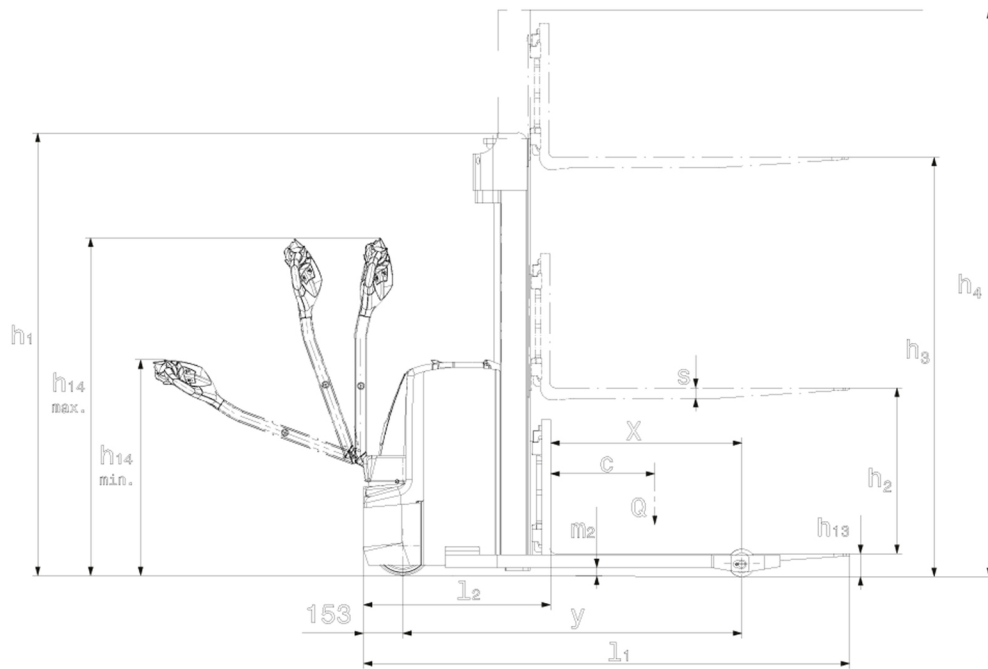

# EJC B12n / 110n / 112n

<b>EJC 110n, EJC 112n</b>	<b>Lift (h3)</b>	<b>Retracted mast height (h1)</b>	<b>Free lift (h2)</b>	<b>Extended mast height (h4)</b>
Duplex mast ZT	2900 mm	1950 mm	100 mm	3373 mm
	3200 mm	2100 mm	100 mm	3673 mm
	3600 mm	2300 mm	100 mm	4073 mm
<b>EJC B12n</b>	<b>Lift (h3)</b>	<b>Retracted mast height (h1)</b>	<b>Free lift (h2)</b>	<b>Extended mast height (h4)</b>
Duplex mast ZT	2500 mm	1750 mm	100 mm	2973 mm
	2900 mm	1950 mm	100 mm	3373 mm
	3200 mm	2100 mm	100 mm	3673 mm
	3600 mm	2300 mm	100 mm	4073 mm

# VDI table

Stand-on: 01/2023

Kennzeichen	1.1	Manufacturer (abbreviated description)		Jungheinrich		
	1.2	Manufacturer's type designation		EJC B12n	EJC 110n	EJC 112n
	1.3	Drive		Electric		
	1.4	Operation		Pedestrian		
	1.5	Load capacity/load	Q kg	1200	1000	1200
	1.6	Load centre distance	c mm	600		
	1.8	Load distance, centre of drive axle to fork	x mm	760	687	
	1.9	Wheelbase	y mm	1300	1171	
	Gewichte	2.1.1	Service weight (incl. battery)	kg	963	805
2.2		Axle load laden front/rear	kg	827 / 1324	650 / 1155	660 / 1360
2.3		Axle load unladen front/rear	kg	682 / 281	565 / 240	575 / 245
Räder/Fahrwerk	3.1	Tyres		Polyurethane (PU)		
	3.2	Tyre size, front		Ø 230 x 70		
	3.3	Tyre size, rear		Ø 85 x 100		Ø 85 x 110
	3.4	Additional wheels		Ø 140 x 54		
	3.5	Wheels, number front/back (x=driven)		1x +1/2		
	3.6	Tread width, front	b <sub>10</sub> mm	510		
	3.7	Tread width, rear	b <sub>11</sub> mm	1350	375	
Grundabmessungen	4.2	Retracted mast height (h1)	h <sub>1</sub> mm	1950		
	4.3	Free lift (h2)	h <sub>2</sub> mm	100		
	4.4	Lift (h3)	h <sub>3</sub> mm	2900		
	4.5	Extended mast height (h4)	h <sub>4</sub> mm	3373		
	4.9	Height of tiller handle in drive position min./max.	mm	785 / 1305	820 / 1310	
	4.15	Height, lowered	h <sub>13</sub> mm	85		
	4.19	Overall length	l <sub>1</sub> mm	1905	1787	
	4.20	Length including fork shank	l <sub>2</sub> mm	716	637	
	4.21.1	Overall width	b <sub>1</sub> mm	1470	800	
	4.21.2	Overall width	b <sub>2</sub> mm	800	-	
	4.22	Fork dimensions	s/e/l mm	40 x 100 x 1150	56 x 185 x 1150	
	4.25	Width across forks	b <sub>5</sub> mm	980	560	
	4.32	Ground clearance centre of wheelbase	m <sub>2</sub> mm	30		
	4.34.1	Aisle width (pallet 1000x1200 sideways)	Ast mm	2416	2046	
	4.34.2	Aisle width (pallet 800x1200 length)	Ast mm	2416	2096	
4.35	Turning radius	W <sub>a</sub> mm	1475	1383		
Leistungsdaten	5.1	Travel speed laden/unladen	km/h	6 / 6		
	5.2	Lift speed laden/unladen	m/s	0.12 / 0.2	0.13 / 0.2	0.12 / 0.2
	5.3	Lowering speed laden/unladen	m/s	0.43 / 0.4		
	5.8	Max. gradeability laden/unladen	%	6 / 13	8 / 16	
	5.10	Service brake		electric	-	electric
E-Motor/Elektronik	6.1	Drive motor, performance S2 60 min	kW	1		
	6.2	Lift motor, performance with S3	kW	1.9	1.7	1.9
	6.3	Battery according to DIN 43531/35/36		no	-	no
	6.4	Battery voltage/nominal capacity	V / Ah	24 / 160		
	6.5	Battery weight	kg	170	156	
	6.6.1	Energy consumption according to EN cycle	kWh/h	0.95	0.85	0.95
	6.6.2	CO2 equivalent as per EN 16796	kg/h	0.5		

Sonstiges	8.1	Type of drive control		AC	
	10.7	Sound level as per EN12053, operator's ear	dB (A)	79	70

- This data sheet according to VDI guideline 2198 only states the technical values of the standard truck. Different tyres, other masts, additional equipment etc. may result in different values.

The German production facilities in  
Norderstedt, Moosburg and Landsberg  
are certified.

ISO 9001  
ISO 14001

 **JUNGHEINRICH**