



# SELF-PROPELLED SCISSOR LIFT

## AS1413 / AS1413E (AS4651 / AS4651E)

### HIGHLIGHTS

#### Flexible Movement with Convenient Operation

- Compact with higher capacity makes demanding jobs easier.

#### More Safety and Cost Effective

- Standard features like motion alarm, overload sensing system and flashing beacons help our customers operate safely.

#### Easy Maintenance and Service Access

- Swing-out component trays and diagnostic system make it easier to access and troubleshooting.





# AS1413 / AS1413E (AS4651/ AS4651E)

## SPECIFICATIONS

Models	AS1413 (AS4651)		AS1413E (AS4651E)	
Measurements	Metric	US	Metric	US
Working Height Max. indoor	15.8 m	51 ft 10 in	15.8 m	51 ft 10 in
Working Height Max. outdoor	10 m	32 ft 10 in	10 m	32 ft 10 in
A-Platform Height-Raised,indoor	13.8 m	45 ft 3 in	13.8 m	45 ft 3 in
Platform Height-Raised,outdoor	8 m	26 ft 3 in	8 m	26 ft 3 in
B-Platform Height-Stowed	1.6 m	5 ft 3 in	1.57 m	5 ft 2 in
C-Platform Width	1.15 m	3 ft 9 in	1.15 m	3 ft 9 in
D-Platform Length	2.64 m	8 ft 8 in	2.64 m	8 ft 8 in
E-Overall Width	1.27 m	4 ft 2 in	1.3 m	4 ft 3 in
F-Overall Length	2.79 m	9 ft 2 in	2.79 m	9 ft 2 in
G-Overall Height-Rails Up	2.72 m	8 ft 11 in	2.76 m	9 ft 1 in
Overall Height-Rails Down	2.2 m	7 ft 3 in	1.96 m	6 ft 5 in
Extended-single Deck	0.9 m	2 ft 11 in	0.9 m	2 ft 11 in
H-Wheelbase	2.22 m	7 ft 3 in	2.22 m	7 ft 3 in
Ground Clearance-Center	11.5 cm	4.5 in	11.5 cm	4.5 in
Productivity				
Max Platform Occupancy(indoor/outdoor)	2/1		2/1	
Platform Capacity	320 kg	700 lbs	320 kg	700 lbs
Platform Capacity-Extension Deck	113 kg	250 lbs	113 kg	250 lbs
Drive Height	Full Height		Full Height	
Drive Speed-Lowered	3.5 km/h	2.2 mph	3.5 km/h	2.2 mph
Drive Speed-Raised	0.8 km/h	0.5 mph	0.8 km/h	0.5 mph
Turning Radius-Outside	2.6m	8 ft 6 in	2.6m	8 ft 6 in
Gradeability-Lowered	25%		25%	
Raise/Lower Speed	80 / 60 sec		80 / 60 sec	
Tires Type	Solid Non-marking		Solid Non-marking	
Tires Size	40.2×12.5 cm	15×5 in	40.2×12.5 cm	15×5 in
Hydraulic System				
Hydraulic Oil Volume	25.5 L	6.7 gal	25.5 L	6.7 gal
Weight				
Machine Weight (CE)	3417kg	7533lbs	3355 kg	7396 lbs

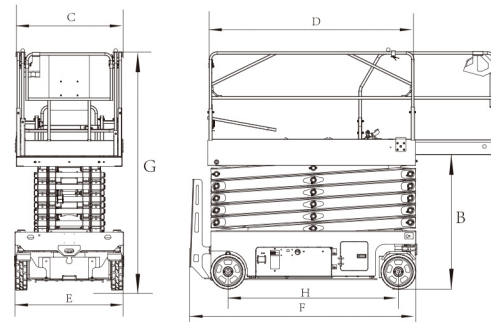

## STANDARD FEATURES

- Push-out Extension Deck
- Foldable Guardrails
- Self-lock Entry Gates
- Proportional Control
- Tilt Alarm with Lift Cut-out
- Overload Sensing System
- Descent Alarm with Flashing Beacons
- Horn/Hour meter
- All Motions Alarm
- Swing-out Component Trays

## OPTIONAL

- Power to Platform
- Platform Anti-Collision Device

Machines in compliant with ANSI A92.20 / CSA / EN280 standard.