

general dimensions

	Ft. & In.	Meters		Ft. & In.	Meters
A — Width of revolving superstructure.....	8' 0 "	2.438	P — Centerline of rear bogie to centerline of rotation	1' 4 "	.407
B — Maximum height of cab above grade.....	9' 7 "	2.921	Q — Distance between centers of axles — tandem axle bogie	4' 1 "	1.244
C — Swing clearance (radius of rear end from axis of rotation)	9' 2 "	2.794	R — Wheel base	16' 1 "	4.902
D — Distance of boom foot pin to axis of rotation	3' 3 "	.990	S — Centerline of rear axle or bogie to rear of carrier frame	6' 1 1/4"	1.861
E — Height of boom foot pin above grade.....	7' 4 1/4"	2.242	T — Overall length of carrier.....	28' 1 3/4"	8.578
F — Max. height of attachment in travel position	9' 6 3/4"	2.914	U — Maximum overall width	8' 0 "	2.438
G — Distance under counterweight to grade	4' 0 "	1.219	V — Track or tread width — rear	6' 5 1/2"	1.969
H — Wheel ground clearance — outrigger cyl.'s extended	0' 9 "	.229	V₁ — Track or tread width — front	6' 7 1/2"	2020
J — Centerline of rotation to centerline of front outrigger box	9' 0 "	2.743	W — Effective length of extended outriggers	15' 9 "	4.801
K — Centerline of front to centerline of rear outrigger box	13' 10 "	4.216	X — Overall width overfloats — outriggers extended	17' 11 "	5.461
L — Boom length — 62 ft. boom — fully retracted	23' 9 "	7.239	Y — Back of carrier cab to centerline of rear axle or bogie	10' 0 "	3.048
L₁ — Boom length — 62 ft. boom w/16' manual insert (fully retracted)	25' 1 "	7.645	Z — Overall length (boom retracted over front).....	32' 11 "	10.032
O — Ground clearance — rear axle housing	0' 11 1/2"	.292	Z₁ — Overall length (boom w/16' manual insert retracted)	34' 3 "	10.439

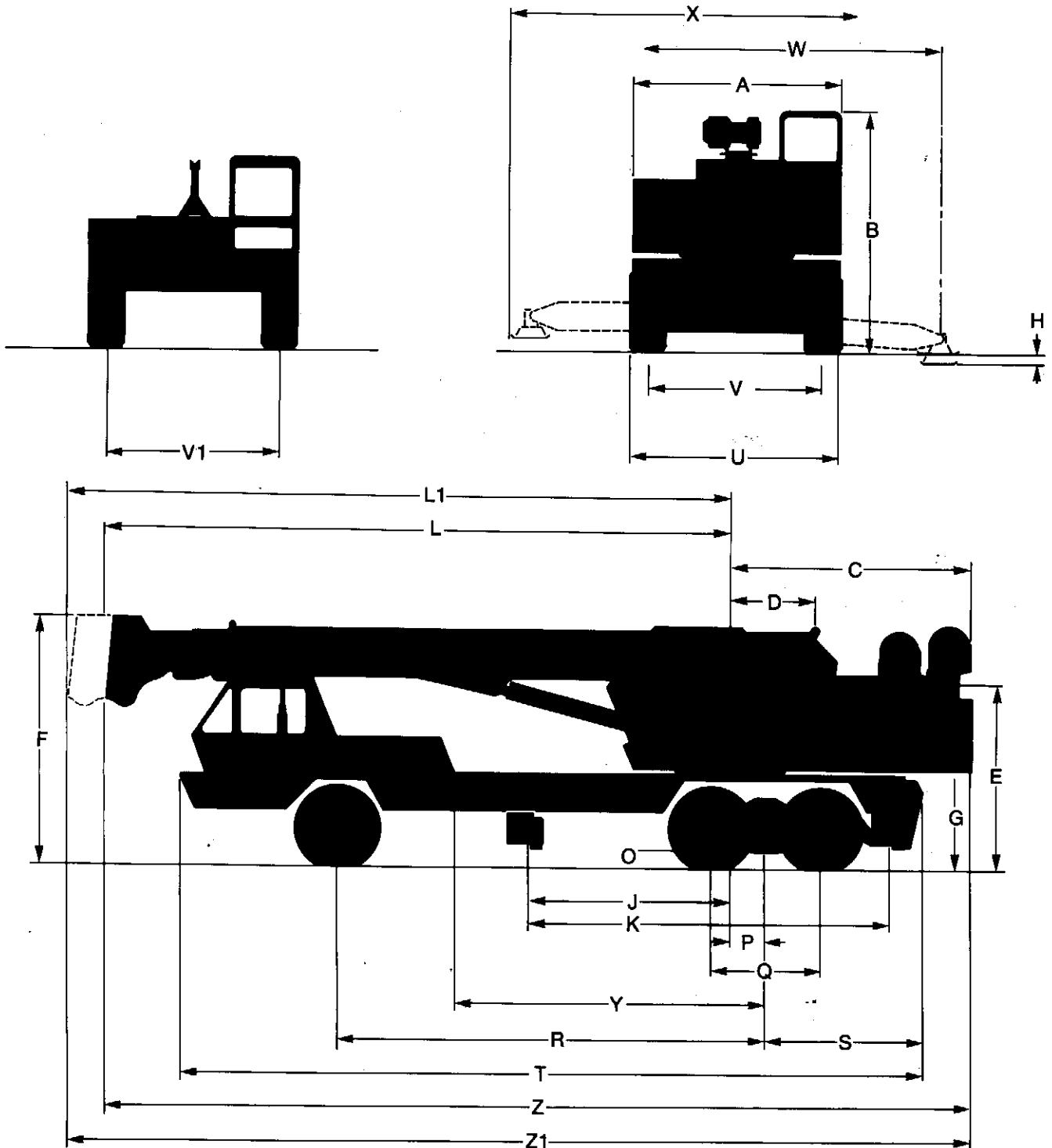

general dimensions

	Ft. & In.	Meters		Ft. & In.	Meters
A — Width of revolving superstructure	8' 0"	2.438	P — Centerline of rear bogie to centerline of rotation	1' 4"	.407
B — Maximum height of cab above grade	9' 7"	2.921	Q — Distance between centers of axles — tandem axle bogie	4' 1"	1.244
C — Swing clearance (radius of rear end from axis of rotation)	9' 2"	2.794	R — Wheel base	16' 1"	4.902
D — Distance of boom foot pin to axis of rotation	3' 3"	.990	S — Centerline of rear axle or bogie to rear of carrier frame	6' 1 1/4"	1.861
E — Height of boom foot pin above grade	7' 4 1/4"	2.242	T — Overall length of carrier	28' 1 3/4"	8.578
F — Max. height of attachment in travel position	9' 6 3/4"	2.914	U — Maximum overall width	8' 0"	2.438
G — Distance under counterweight to grade	4' 0"	1.219	V — Track or tread width — rear	6' 5 1/2"	1.969
H — Wheel ground clearance — outrigger cyl.'s extended	0' 9"	.229	V₁ — Track or tread width — front	6' 7 1/2"	2020
J — Centerline of rotation to centerline of front outrigger box	9' 0"	2.743	W — Effective length of extended outriggers	15' 9"	4.801
K — Centerline of front to centerline of rear outrigger box	13' 10"	4.216	X — Overall width overfloats — outriggers extended	17' 11"	5.461
L — Boom length — 62 ft boom — fully retracted	23' 9"	7.239	Y — Back of carrier cab to centerline of rear axle or bogie	10' 0"	3.048
L₁ — Boom length — 62 ft boom w/16' manual insert (fully retracted)	25' 1"	7.645	Z — Overall length (boom retracted over front)	32' 11"	10.032
O — Ground clearance — rear axle housing	0' 11 1/2"	.292	Z₁ — Overall length (boom w/16' manual insert retracted)	34' 3"	10.439

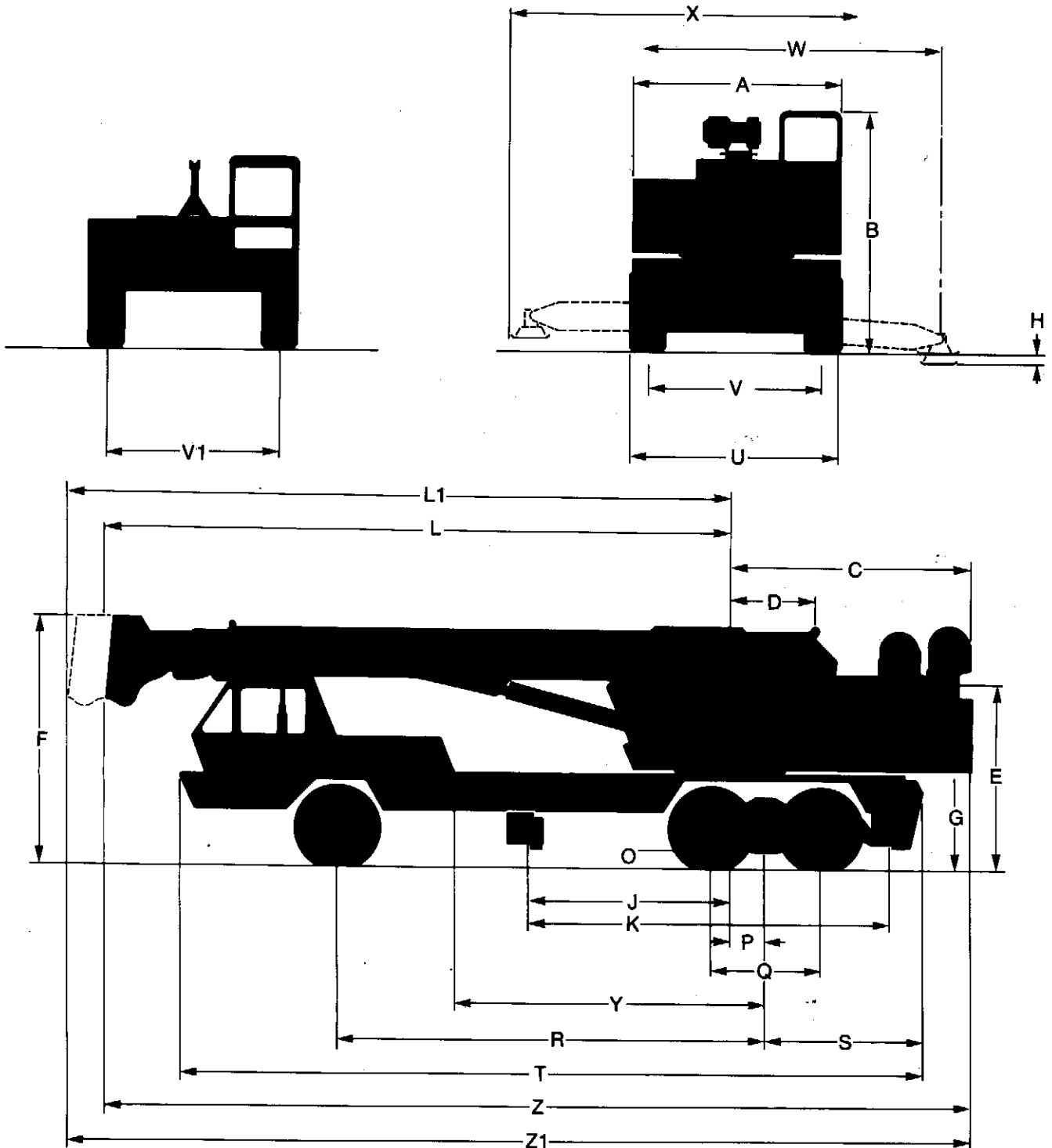

lifting capacities

26' TO 62' BOOM • LOAD RATINGS IN POUNDS • CLASS 10-66

POWERED BOOM 26 TO 62 FEET															
Rad. In Ft.	WITH OUTRIGGERS										Rad. In Ft.	WITHOUT OUTRIGGERS			
	Over Rear					Over Side						Over Rear	Over Side		
	26 Feet		44 Feet		62 Feet	26 Feet		44 Feet		62 Feet					
∠	Lbs.	∠	Lbs.	∠	Lbs.	∠	Lbs.	∠	Lbs.	∠	Lbs.	∠	Lbs.	∠	Lbs.
10	60	40000	74	35000			60	40000	74	35000			10	20000	16000
12	55	36500	71	32000			55	36500	71	32000			12	16500	12000
14	49	30500	69	28000	75	*24000	49	30500	69	28000	75	*24000	14	13600	9000
16	43	26500	66	25000	74	22500	43	26500	66	25000	74	22500	16	11200	7200
18	36	24000	63	23000	72	21000	36	24000	63	23000	72	21000	18	9400	5900
20	27	22000	60	21000	70	20000	27	22000	60	21000	70	20000	20	8000	4800
25			51	16200	65	16200			51	15500	65	15500	25	5600	2800
30			42	12400	60	12400			42	11000	60	11000	30	4100	1400
35			31	9700	54	9700			31	8500	54	8500	35	2800	600
40			11	7900	47	7900			11	6600	47	6600	40	2000	
45					40	6400					40	5200	45	1400	
50					32	5300					32	4300	50	900	
55					21	4400					21	3600	55	600	
59					0	3800					0	3200	59		

*Load rating for maximum 75° boom elevation will be at longer radius than indicated.

Do not exceed 56' radius

27'6" TO 78' BOOM • LOAD RATINGS IN POUNDS • CLASS 10-57

POWERED BOOM 27'-6" TO 63'-6" WITH MANUAL INSERT RETRACTED															
Rad. In Ft.	WITH OUTRIGGERS										Rad. In Ft.	WITHOUT OUTRIGGERS			
	Over Rear					Over Side						Over Rear	Over Side		
	27'-6"		45'-6"		63'-6"	27'-6"		45'-6"		63'-6"					
∠	Lbs.	∠	Lbs.	∠	Lbs.	∠	Lbs.	∠	Lbs.	∠	Lbs.	∠	Lbs.	∠	Lbs.
10	61	40000	75	*35000			61	40000	75	*35000			10	20000	16000
12	57	36500	72	32000			57	36500	72	32000			12	15700	11200
14	51	30500	70	28000	75	*25000	51	30500	70	28000	75	*25000	14	12800	8200
16	45	26500	67	25000	74	22500	45	26500	67	25000	74	22500	16	10400	6300
18	39	24000	64	23000	73	21000	39	24000	64	23000	73	21000	18	8600	5100
20	32	22000	61	21000	71	20000	32	22000	61	21000	71	20000	20	7200	4000
25			52	15400	66	15400			52	14700	66	14700	25	4800	2000
30			44	11600	61	11600			44	10200	61	10200	30	3200	600
35			34	8900	55	8900			34	7700	55	7700	35	2000	
40			16	7100	49	7100			16	5700	49	5700	40	1200	
45					42	5500					42	4300	45	600	
50					34	4400					34	3500	50		
55					24	3500					24	2800	55		
59					12	2900					12	2300	59		
POWERED BOOM WITH EXTENDED MANUAL INSERT 78' MAXIMUM															
65						3200						2900	65		
70						2700						2300	70		
75						2300						1800	75		

*Load rating for maximum 75° boom elevation will be at longer radius than indicated.

HOIST REEVING 1/2 DIA. WIRE ROPE MINIMUM BREAKING STRENGTH 23000 LBS.							
Parts of Line	1	2	3	4	5	6	7
Maximum Load Lbs.	6250	12500	18750	25000	31250	37500	40000

Operating radius is the horizontal distance from the axis of rotation before loading, to the center of the vertical hoist line or tackle with load applied. Boom angles shown are with rated loads applied and provide an approximation of the operating radius. For rated loads, do not exceed the specified operating radius. Crane load ratings are for machines with 4000 pounds of counterweight and do not exceed 85% of the tipping loads. Ratings above the heavy line are based on the machines hydraulic or structural competence and not on the machine stability. Weights of hooks, hook blocks, slings, and all other load handling devices, except hoist rope shall be considered a part of the load, crane load ratings with outriggers are based on outriggers fully extended and set to a distance of 7'-10 1/2" from the longitudinal axis of the carrier to the outrigger float pivot connection with wheels within the boundary of the outriggers unloaded.

Crane load ratings without outriggers depend on tire capacity and condition of tires, inflated per table. Crane load ratings are based on freely suspended loads with the machine leveled and standing on a firm uniform supporting surface. Practical work loads depend on supporting surface, wind, and other factors affecting stability, hazardous surroundings, experience of personnel and proper handling, all of which must be taken into account by the operator. Positioning or operation at radii and boom or jib lengths beyond the maximums and minimums shown, is not intended or approved. For boom lengths not shown, use load ratings of next longer boom. Powered boom has no sequence pattern for extension. Each telescopic section is power extendible a distance of 18 Feet. The maximum powered boom load which may be telescoped is limited by hydraulic pressure, boom angle, boom lubrication, etc. It is safe to attempt to telescope any load within the limits of the load rating chart.

NOTE: OPERATION OF THIS EQUIPMENT IN EXCESS OF LOAD RATINGS AND DISREGARD OF INSTRUCTIONS VOIDS THE WARRANTY.

MAXIMUM JIB LOAD RATINGS IN POUNDS

Min. Boom Angle	15 or 20 Foot Jib		
	Offset Angle Degrees		
	0°	10°	20°
75°	8500	6000	5000
70°	6000	5000	4500
65°	5000	4500	4000
60°	4000	3500	3000
50°	2500	2250	2000
40°	2000	1750	1500
30°	1500	1400	1300

Use of outriggers is recommended.

Maximum jib and extended manual insert load ratings are based on structural competence. Ratings at any radius shall not exceed the powered boom load ratings at the same radius and shall not exceed maximum load ratings shown.

For bucket ratings on jib, deduct 20% from maximum jib load ratings. Maximum jib operating radius shall not exceed the operating radius of the powered boom for any given length setting.

MAX. LOAD RATINGS IN LBS. FOR JIB & EXTENDED MANUAL INSERT

Manual Insert Extended	Min. Boom Angle	Jib with Manual Insert Extended or Retracted		
		15 or 20 Foot Jib		
		Offset Angle Degrees		
		0°	10°	20°
12500	75°	6250†	6000	5000
12500	70°	6000	5000	4500
12500	65°	5000	4500	4000
12500	60°	4000	3500	3000
12500	50°	2500	2250	2000
12000	40°	2000	1750	1500
9700	30°	1500	1400	1300
8400	20°			
7900	10°			
7600	0°			

Use of outriggers is recommended.

† Maximum jib load rating with manual insert retracted is 8500 lbs.

DEDUCTIONS TO BE MADE FROM POWERED BOOM LOAD RATINGS

Equipped With Pounds	15 or 20 Ft. Stowed Jib	15 or 20 Ft. Erected Jib
	400	800

TIRE INFLATION

Size	Pressure
15:00 x 22.5	75 PSI

working ranges

Meters

.407

1.244

4.902

1.861

8.578

2.438

1.969

2020

4.801

5.461

3.048

10.032

10.439

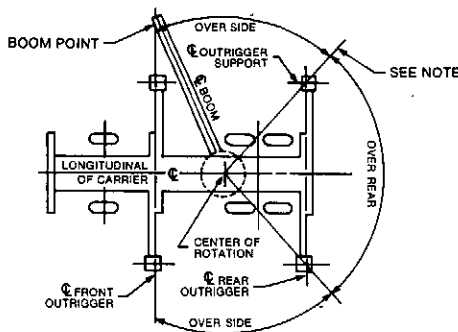
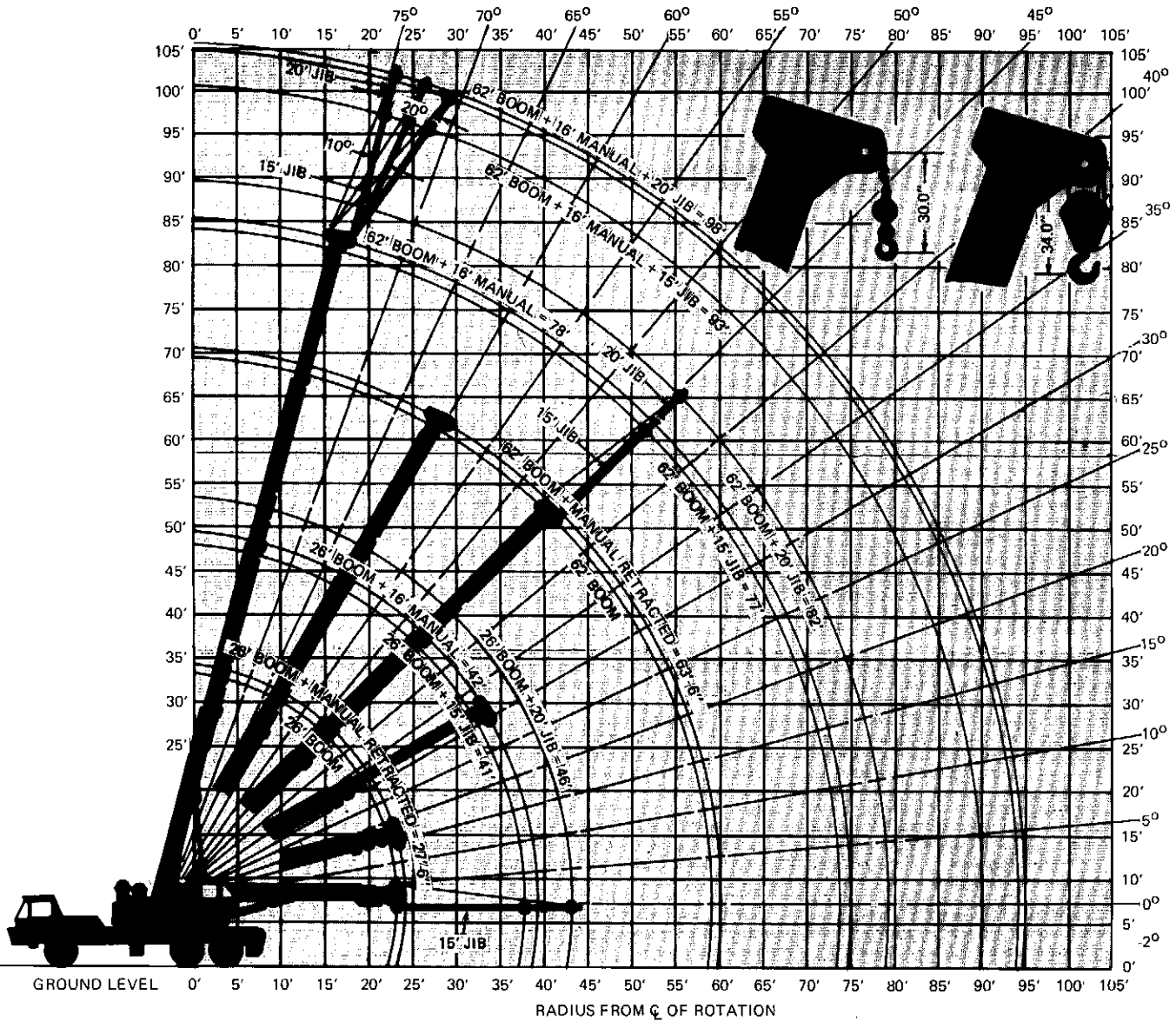

ON OUTRIGGERS

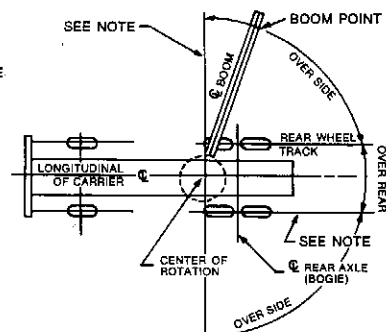

ON RUBBER

NOTE
THESE LINES DETERMINE
THE LIMITING POSITION OF
ANY LOAD FOR OPERATION
WITHIN WORKING AREAS
INDICATED.

AREAS OF OPERATION

P&H/T-200

- Exclusive P&H Volu-Matik® hydraulic system with separate circuits and independent pumps.
- Less than 9'7" overall height.
- Powerful 8' wide Harnischfeger-built 6 x 4 carrier.
- Exclusive P&H hydraulic outriggers with independent horizontal and vertical motions. Self-storing floats.

specifications

UPPER MACHINERY



CONTROLS: Four long hand control levers for swing, main, boom hoist, and telescope. Boom hoist and telescope may also be foot operated. Swing brake is foot operated with hand operated brake lock. Foot throttle (left foot) controls carrier engine; hand throttle is optional. Dial-A-Swing® Control.

SWING UNIT: Hydraulic motor driven through double reduction gear case. 360 degree continuous rotation to 3.3 RPM.



FASTENING TO LOWER: Double row ball bearing Swing Circle® with swing gear integral.

SWING GEAR: Internal spur gear 40" (1016 mm) P.D.

SWING BRAKE: Caliper-disc type mounted on motor shaft of gear case. Hydraulically actuated and locked.



MAIN WINCH: Gearmatic #11 SECR, single and equal speed up and down, mounted on the revolving frame. Free fall optional.

DRUM: Smooth 9½" (241 mm) P.D., 13" (330 mm) wide.

CABLE: ½" (12.7 mm) dia. 8 x 19 spin resistant with 7 x 7 I.W.R.C.

DRUM CAPACITY: 526 ft. (160 m) 7 layers.

LINE PULL (MAX.): 7840# (3556 kg) first layer.

LINE PULL (PERMISSIBLE): Per part of line 6250# (2835 kg).

LINE SPEED (MAX.): 322 FPM (98 m/M) seventh layer.

AUXILIARY WINCH (OPTIONAL): Gearmatic #11 SCR, single speed with high speed lowering, mounted on revolving frame. Free fall optional.

DRUM: Smooth 9½" (241 mm) P.D., 13" (330 mm) wide.

CABLE: ½" (12.7 mm) dia. 8 x 19 spin resistant with 7 x 7 I.W.R.C.

DRUM CAPACITY: 526 ft. (160 m) 7 layers.

LINE PULL (MAX.): 7840# (3556 kg) first layer.

LINE PULL (PERMISSIBLE): Per part of line 6250# (2835 kg).

LINE SPEED RAISING (MAX.): 211 FPM (64 m/M) seventh layer.

LINE SPEED LOWERING (MAX.): 1160 FPM (354 m/M) seventh layer.

AUXILIARY WINCH (OPTIONAL): Gearmatic #11 SECR, single and equal speed up and down, mounted on revolving frame. Free fall optional.

DRUM: Smooth 9½" (241 mm) P.D., 13" (330 mm) wide.

CABLE: ½" (12.7 mm) dia. 8 x 19 spin resistant with 7 x 7 I.W.R.C.

DRUM CAPACITY: 526 ft. (160 m) 7 layers.

LINE PULL (MAX.): 7840# (3556 kg) first layer.

LINE PULL (PERMISSIBLE): Per part of line 6250# (2835 kg).

LINE SPEED (MAX.): 211 FPM (64 m/M) seventh layer.



BOOM HOIST: Two 7" (178 mm) dia. cylinders-double acting. Hydraulic powered raising and lowering with holding valve.

BOOM TELESCOPE: Two 5" (127 mm) dia. cylinders-double acting. Hydraulic powered extending and retracting with holding valve.

OPERATOR'S CAB: All weather, full vision with safety glass. Heater and defroster, windshield wiper. Contains all instrumentation and crane function controls. Includes: Gage for hydraulic oil temperature, engine gage cluster for fuel level, engine oil pressure, engine water temperature, and voltmeter. Engine start and shut off switches, signal horn.

CAB EQUIPMENT (OPTIONAL): Boom angle indicator, drum turn indicator, hand throttle assembly, windshield washer, seat belt, dome light, trouble light, remote control of outriggers, remote control of outriggers and carrier.

COUNTERWEIGHT: Fixed, 4000# (1814 kg).

HYDRAULIC SYSTEM

PUMP DRIVE: Gear box, driven off front of carrier engine with disconnect for traveling.

PUMPS: Two double pumps standard and one single pump for optional auxiliary winch mounted on pump drive. One single pump engine driven. Total delivery 169 G.P.M. (640 l/m).

OIL RESERVOIR: 155 gal. (587 l) mounted on right hand side of carrier frame.

OIL COOLER: Oil to air round tube and fin type.

CONTROL VALVES: Four independent four-way valves. Additional valve with optional auxiliary winch.

FILTERS: Return line filters — full flow — 10 micron.

CARRIER

TYPE: P&H 6 x 4.

WEIGHT: 24800# (11249 kg). Including swing circle, hydraulic outriggers and 15:00 x 22.5 tires.

FRAME: 50,000 P.S.I. min. yield high strength steel reinforced channel section.



OUTRIGGERS: Hydraulic scissors type — eight double acting cylinders for independent horizontal and vertical motion of each beam, solenoid valve controlled.

OUTRIGGER HOUSING: Two independent, removable housings front and rear.

OUTRIGGER BEAMS: 100,000 min. yield high strength steel box with self-storing floats. Ends extended from center of carrier: 8' - 3" (2.51 m).



POWER PLANT: Cummins Diesel V8-210 202 HP at 3300 R.P.M., 390 lb. ft. max. torque at 1900 R.P.M., 8 cyl., 4¾" bore, 3¾" stroke, 504 cu. in. displacement.

ELECTRICAL EQUIPMENT: 12 volt negative ground, two 200 amp. hr. battery; 42 amp. alternator.

AIR CLEANER: Farr Pamic Dry Type.

FUEL TANK: 65 gal. (246 l) capacity.

RADIATOR: Vertical flat tube and fin type core. Thermostatic temperature control.

CLUTCH: Lipe-Rollway 14" 1dlb.

TRANSMISSIONS: MAIN: Spicer model 5652A, five speeds forward, one reverse. AUXILIARY: Spicer model 7041, four speeds. High gear speeds to 50 M.P.H. Maximum grade 45%. At low gear speed of 1.75 M.P.H.

BRAKES — SERVICE: Rockwell Standard Stopmaster Wedge Type on front. Stopmaster Fail Safe on all four rear wheels. Brake linings: 15" (381 mm) dia. x 6" (152 mm) on front, 15" (381 mm) dia. x 7" (178 mm) on rear.

BRAKES — PARKING: Stopmaster Fail Safe spring set air released.

FRONT AXLE: Rockwell Standard FL901.

REAR AXLE: Rockwell Standard Model S.Q.H.D., single reduction 7.80:1 with interaxle differential.

SUSPENSION: Front: Leaf type spring suspension. Rear: Solid bogie mounted with torque rods.

STEERING: Ross steering gear with Vickers power assist booster. 18" (457 mm) dia. steering wheel.

TIRES: Std. 15:00 x 22.5 — 14 P.R. tubeless. Opt. 15:00 x 22.5 — 16 P.R. tubeless.

CAB: One man type, steel with safety glass, offset left side of engine.

FRONT AXLE: Rockwell Standard FL901.



REAR AXLE: Rockwell Standard Model S.Q.H.D., single reduction 7.80:1 with interaxle differential.

SUSPENSION: FRONT: Leaf type spring suspension. REAR: Solid bogie mounted with torque rods.



STEERING: Ross steering gear with Vickers power assist booster. 18" (457 mm) dia. steering wheel.

TIRES: Std. 15:00 x 22.5 — 14 P.R. tubeless. Opt. 15:00 x 22.5 — 16 P.R. tubeless.

CAB: One man type, steel with safety glass, offset left side of engine.

CAB EQUIPMENT: Heater and defroster. All roading controls and instrumentation, including: Illuminated instrument panel with speedometer, tachometer, voltmeter, fuel gage, oil pressure gage, water temperature gage, air pressure gage, low air pressure indicator light, air brake valve, windshield wiper, horn, rear view mirror, and seat belt.

CAB EQUIPMENT (OPTIONAL): Windshield washer, West Coast right and left hand mirror, amber rotating light.

LIGHTS: Dual headlights, tail lights, stop lights, directional signal lights front and rear with emergency flasher, front, rear, and side clearance lights, and rear license plate light.

EQUIPMENT (STANDARD): Front bumper, full fenders, skirts, frame decking with anti-skid surface, and hood. Front and rear towing hooks, and boom rack mounted on front of carrier.

EQUIPMENT (OPTIONAL): Back up warning device, starting aid, flood lights, and anti-two block assembly.

ATTACHMENTS



BOOM (STANDARD): Three piece consisting of a base and two hydraulically extended and retracted sections. Removable boom point with four boom point sheaves. 26'-2" (7.97 m) Retracted length, 62'-2" (18.95 m) extended length.

INSERT (OPTIONAL): 16' (4.9m) in length with removable boom point. Manually pinned section which can be hydraulically making boom length 78'-2" (23.8 m) and retracted making boom length 27'-8" (8.43 m).

JIBS (OPTIONAL): 15'-0" (4.6 m) with single point sheave. Storage on boom base section. 20'-0" (6.1 m) with single point sheave. Storage on boom base section.

HOOK BLOCKS (OPTIONAL): Three sheaves with swivel hook and safety latch. Single sheave with swivel hook and safety latch (10 ton/9.07 m. ton). Weighted hook with swivel and safety latch (5 ton/4.53 m. ton).

132.8

VEHICLE WEIGHTS: Includes counterweight, main winch, and 62 ft. boom in travel position.

FRONT	REAR	G.V.W.
15775	31335	47110

Effect of removing the following:

Front outrigger assembly (housing, beams & cyls.)	- 1120	- 880	- 2000
Rear outrigger assembly	+ 600	- 2600	- 2000
Counterweight:	+1830	- 5830	- 4000

Effect of adding the following:

Auxiliary winch	- 320	+1140	+ 820
15 ft. jib	+ 500	+ 100	+ 600
20 ft. jib	+ 575	+ 125	+ 700
16 ft. manual insert	+1030	0	+1030
Three-sheave block	+ 590	- 170	+ 420

All values in pounds.



NOTE: All designs, specifications and components of the equipment described above are subject to change at the manufacturer's sole discretion at any time without advance notice. Data published herein is informational in nature and shall not be construed to warrant suitability of the machine for any particular purpose as performance may vary with the conditions encountered. The only warranty applicable is our standard written warranty for this machine. Manufactured and sold in conformance with U. S. Department of Commerce Commercial Standard CS-90-58.

Address inquiries to:



Harnischfeger

P&H

MILWAUKEE, WISCONSIN 53201