

 **JINT** | 金泰机械

# SD28

多功能钻机  
Hydraulic Rotary  
Drilling Rig

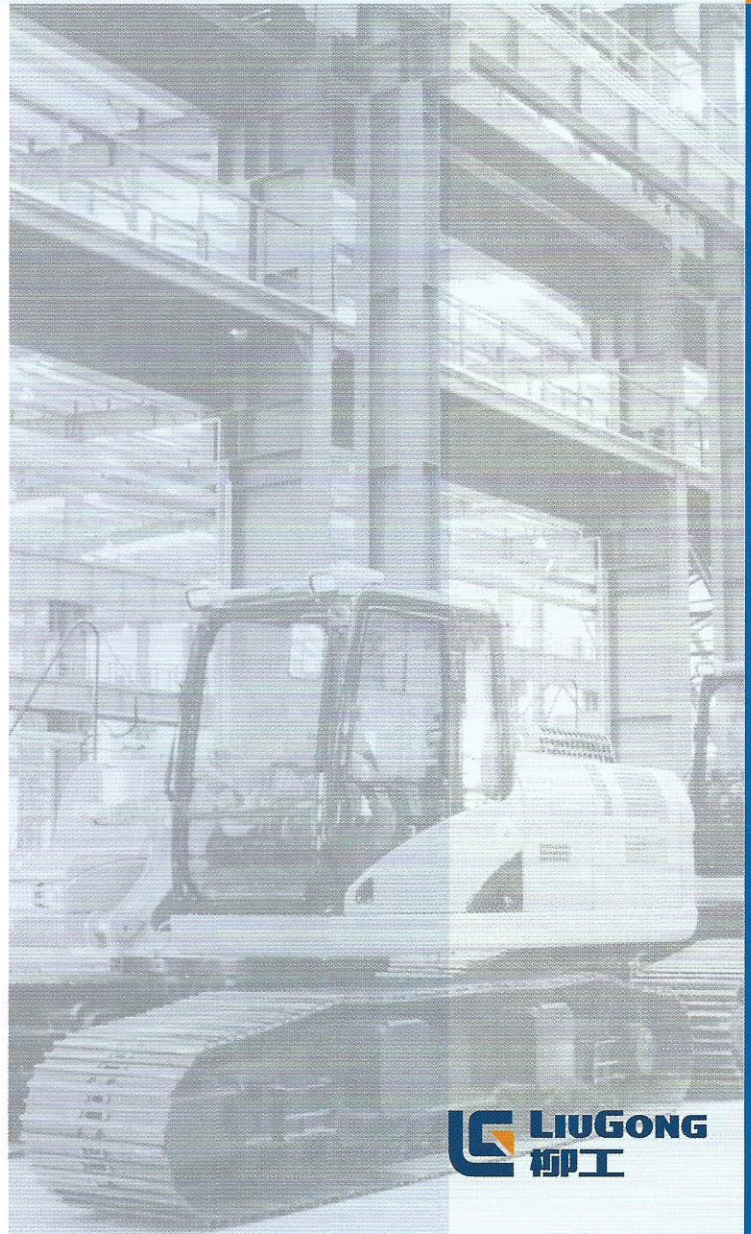





# SD28多功能钻机

## SD28 Hydraulic Rotary Drilling Rig

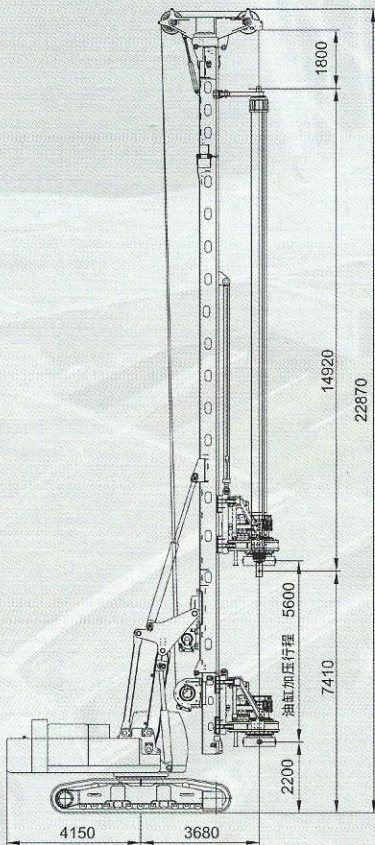

油缸加压式 Crowd cylinder type

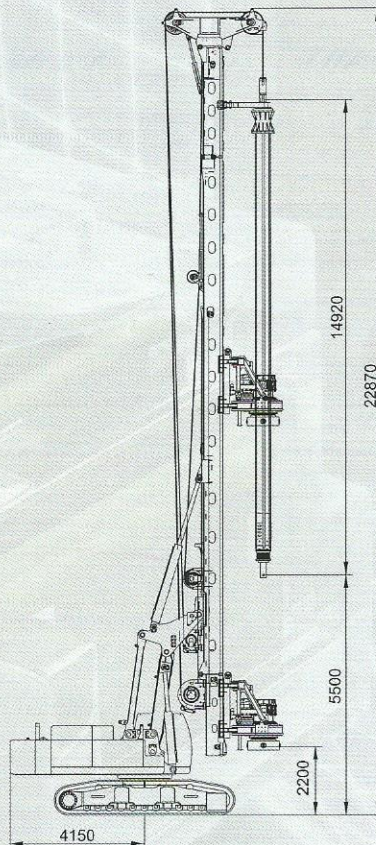

卷扬加压式 Crowd winch type

SD28多功能钻机融合了现代液压桩工机械新技术和新工艺,主要性能参数达到了国际同类产品先进水平,关键零部件采用国际品牌产品。整机操作轻便灵活,作业效率高。广泛应用于高层建筑、桥梁工程、水利建设等地基基础工程施工。是大口径桩基础工程施工的理想设备。

SD28 Hydraulic Rotary Drilling Rig, its main performance reaches advanced level of its same kind in the world. Its key parts use world famous products. It can be flexibly operated and has high efficiency, widely used in the construction of tall building, bridge and water conservancy.





## 主机 Base Machine

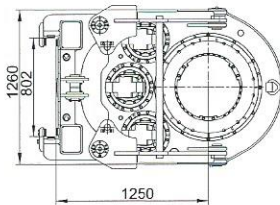
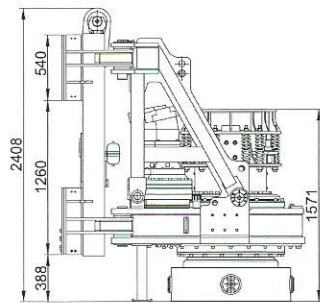

### 发动机/Engine

柴油发动机/Diesel	QSM11-C
额定功率/Diesel engine power(kW)	263
发动机最大转速/Max.rotation speed (rpm)	1900

### 液压系统/Hydraulic system

最大液压系统流量 Maximum hydraulic system flow (L/min)	2 x 380
最大液压系统压力 Maximum hydraulic pressure(bar)	330

### 动力头/Rotary head

回转扭矩/Rotary torque (kN.m)	286
回转速度/Rotary speed (r/min)	6 ~ 30

### 底盘/Chassis

可伸缩下底盘/Extendable chassis lower part	JT80
履带板宽度/Width of triple grouser track shoes (mm)	800
底盘长度/Chassis length (mm)	5680
底盘宽度(缩进/伸出)/ Chassis width (contraction/extension) (mm)	3300 ~ 4400
牵引力/Towing force (kN)	500
行走速度/Crawler speed (km/h)	1.8

运输重量/Transport weight	SD28	SD28W
-----------------------	------	-------

运输重量/Transport weight(kg)	73000	74000
---------------------------	-------	-------

其中:配重/Wherein: counter weight(kg)	15000	15000
-----------------------------------	-------	-------

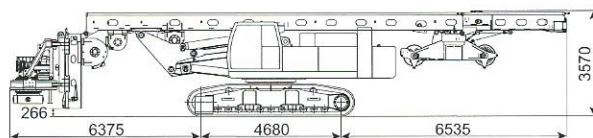

油缸加压式 Crowd cylinder type

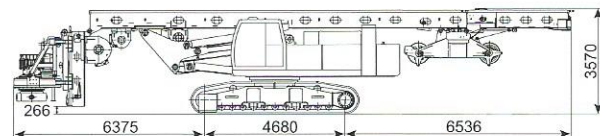

卷扬加压式 Crowd winch type



# SD28多功能钻机技术参数

## Technical Data of SD28 Hydraulic Rotary Drilling Rig

### 钻进参数 Drilling Parameter

主要尺寸/Dimensions(mm)	SD28	SD28W
L1	20400	20400
L2	9175	13575
L3	3575	3575
钻孔直径/ Drilling diameter(mm)		
未带护筒 /Uncased	2400	2400
带护筒/Ccased	2000	2000
护筒长度/Length of case(m)		
不配摇管机时 /W/O oscillator	H-0.6	H-0.6
配摇管机时/With oscillator	H-1.8	H-1.8

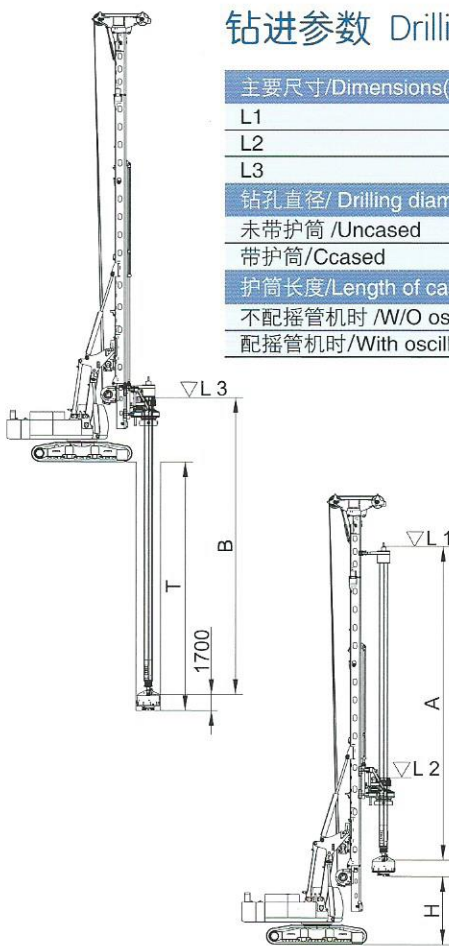

### 备注 Remarks

钻孔深度基于以下参数:

- 钻头长度1.7米
- 自锁钻杆时, 钻深应减去钻杆节数乘0.2米
- 其他长度的钻杆可根据要求制造
- 钻杆重量+钻头重量需与卷扬机拉力相适应
- 选配钻杆需考虑深度、扭矩和加压力三者之间匹配

Drilling data are based on:

- Length of drilling bit 1.7m
- Drilling depth for locked Kelly bars to be reduced by number of Kelly sections multiplied by 0.2m
- Others Kelly bar of different lengths could be available on request
- Weight of Kelly bar + bit must be checked for sufficient winch capacity
- Appropriate Kelly type to be selected according to depth, torque and crowdpressure

### 钻深表(凯式钻杆)/Drilling depth(Kelly)(\*推荐使用/Recommended)

钻杆型号/Type of Kelly bar	A(m)	B(m)	钻杆重量 Weight(kg)	H(m)	T(m)
Φ470/4自锁式/Linter-locking type	13.3	45.6	9390	5.4	43
Φ470/4自锁式/Linter-locking type	16.6	58.2	11040	2.1	56
Φ470/5摩擦式/Friction type	15.9	69.9	10310	2.8	68
Φ540/6摩擦式/Friction type	16.5	87.0	14170	2.2	85

其他规格可以根据需求订制 Some other specifications are optional according to user's special requirement.

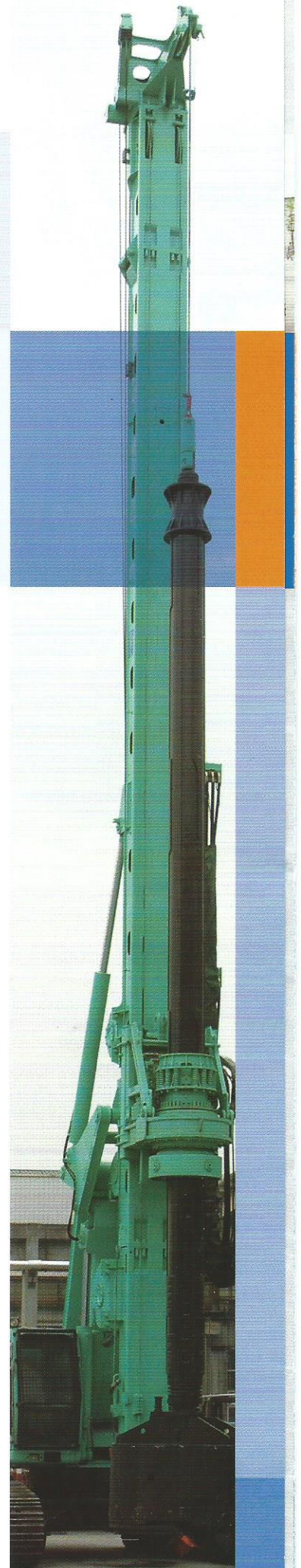



\*注意：技术参数修改恕不另行通知 (Technical data subject to change without notice)

# SD28多功能钻机技术参数

## Technical Data of SD28 Hydraulic Rotary Drilling Rig



型号/Type	SD28	SD28W
桅杆高度/Height of mast (mm)	22870	22870
主机重量(不含钻具)/Weight of base machine(without drilling tools)(kg)	73000	74000
加压系统/Crowd system		
加减压行程/Stroke (mm)	5700	10000
加压力/Pressure force (kN)	250	250
起拔力/Pulling force (kN)	250	250
主卷扬机/Main winch		
单绳拉力/Single line pull (kN)	250	250
钢丝绳直径/Rope diameter (mm)	30	30
最大提升速度/Line speed max. (m/min)	65	65
副卷扬机/Auxiliary winch		
单绳拉力/Single line pull (kN)	75	75
钢丝绳直径/Rope diameter (mm)	18	18
最大提升速度/Line speed max. (m/min)	45	45



# 400-820-8326

本公司保留更改样本技术规格和配置的权利而无需另行通知并免费。  
此型号的设备可以有特殊配置。样本中技术参数不考虑能量损失。

样本中可能有打印错误

Technical specifications are subject to change without prior notice and incurring responsibility for machines previously sold. The shown machines may have special equipment. Technical data do not consider power losses.

Error and misprints reserved

更多信息请访问：  
[www.jintai-sh.com](http://www.jintai-sh.com)

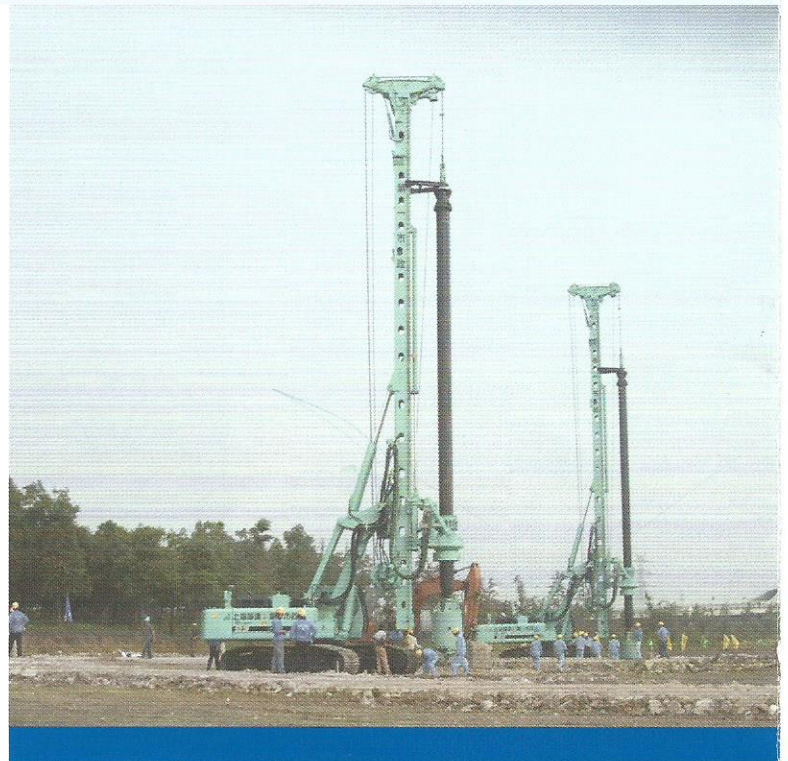

**上海金泰工程机械有限公司**  
SHANGHAI JINTAI ENGINEERING MACHINERY CO.,LTD

公司地址：上海安亭洛浦路45号  
Address: 45 Luopu Road Anting Shanghai  
Fax: 86-21-59577391  
E-mail: [webmaster@jintai-sh.com](mailto:webmaster@jintai-sh.com)