



Excavator SWE 150E



Operating Weight	14.8t(steel track)
Engine Power	84kW/2200rpm
Engine Brand	ISUZU
Standard Bucket Capacity	0.6m ³
Max. Digging Depth	5.64m

Excavator SWE150E

Parameter

ENGINE

Brand	ISUZU
Model	GI-4JJ1XKSC
Type	4-cylinder, 4-stroke, water cooled, turbocharged
Displacement	2.999L
Power	84kW/2200rpm

ELECTRIC SYSTEM

Nominal Voltage	24V
Batteries	120Ah
Alternator	24V-50A
Starter	24V-4kW

DRIVE

Max.Travel Speed (2nd/1st)	5.4/3.3km/h
Gradeability	35°
Max. Traction	115kN

UNDERCARRIAGE

Undercarriage Width	2600mm
Track Height	825mm
Tumbler Distance	3000mm
Track Length	3735mm
Shoe Width	600mm

DIMENSIONS

Counterweight Clearance	915mm
Tail Swing Radius	2350mm
Shipping Length	7815mm
Shipping Width	2600mm
Shipping Height	2825mm

WORKING RANGES

Max. Cutting Height	8630mm
Max. Loading Height	6130mm
Max. Digging Depth	5640mm
Max. Vertical Wall Digging Depth	4540mm
Max. Digging Reach	8355mm
Max. Digging Reach (Ground)	8230mm
Bucket Digging Force	100kN
Stick Digging Force	72.5kN
Ground Pressure	36kPa
Swing Speed	11.1rpm

CAPACITY

Fuel Tank	245L
Hydraulic Tank	150L

HYDRAULIC SYSTEM

Main Pumps	
Type	2 piston pumps
Displacement	2x139 L/min
Working Pressure	31.4/34.3 MPa

Excavator SWE 150E

Working Ranges

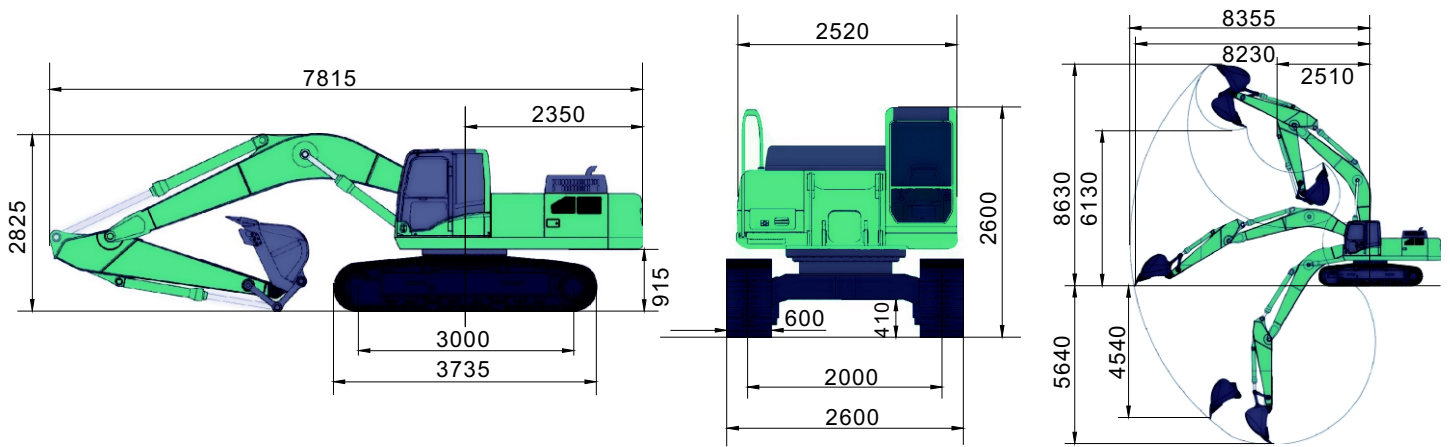

Load Capacity

A(m) \ B(m)	MAX		7m		6m		5m		4m		3m	
	Front(kg)	Side(kg)	Front(kg)	Side(kg)	Front(kg)	Side(kg)	Front(kg)	Side(kg)	Front(kg)	Side(kg)	Front(kg)	Side(kg)
6.0	2720*	2720*	—	—	—	—	2830*	2830*	—	—	—	—
5.0	3100*	2200	—	—	3180*	3180*	3570	3570	—	—	—	—
4.0	2940*	2340*	—	—	3220*	2400	3500*	3500*	3400*	2600	—	—
3.0	2730*	1700	—	—	3440*	2510	3600*	3600*	3700*	3200	5000*	5000*
2.0	2700	1690	2100	2000	3580	2640	3820*	3820*	3900*	3400	5500*	5200*
1.0	2680	1690	2200	2100	3700	2500	4500	4000	4500*	4000	6110	5600
0.0	2640	1680	—	—	3240	2640	4800	4300	5200*	4500	5770	5540
-1.0	2700	1900	—	—	3540	2700	5210	4220	5120	4500	8500	5400
-2.0	3320	2200	—	—	4000	2810	5270	4200	5100	4430	8300	5300
-3.0	3790	2380	—	—	4570	2970	5110	4050	4900	3500	8100	5200
-4.0	4400	2580	—	—	—	—	—	—	4800	3000	—	—

Notes:

- 1) Load with * is limited by hydraulic capacity and based on ISO 10567. Rated loads do not exceed 87% of hydraulic capacity.
- 2) Load without * is limited by tipping load and based on ISO 10567. Rated loads do not exceed 75% of tipping load.

■ SUNWARD INTELLIGENT EQUIPMENT CO.,LTD.

Add: Sunward Intelligent Industrial Park, Xingsha, Changsha, 410100, China.

Tel: (0086-731) 83572 828 Fax: (0086-731) 83572 661

E-mail: international@sunward.com.cn

Web: www.sunward.com.cn

■ SUNWARD EUROPE HEAVY INDUSTRY NV

Add: Nijverheidspark 3, 3580 Beringen, Belgium

Tel: (0032-011) 434666

E-mail: eu@sunward.cc