



Standard Features

- Proportional controls
- Self-lock gate on platform
- Extended platform
- Drivable at full height
- Non marking tire
- 4x2WD
- Explosion-proof of the tubing
- Automatic brake system
- Emergency lowering system
- Emergency stop button
- Tilt sensor with alarm
- All motion alarm
- Horn
- Hour meter
- Safety brackets
- Forklift pockets
- Charger protection
- Flashing beacon

Options Features

- Overload sensor with alarm
- AC power to platform
- Single extension platform

Models	XE50MINI/ED PLUS	XE60MINI/ED PLUS
	Metric system	Metric system
Working height max	5m	6.3 m
Platform height max	3m	4.3 m
Outreach max	0.55m	0.55m
Lifting capacity	240kg	240kg
Lifting capacity (Extended platform)	100kg	100kg
Weight	550kg	615kg
Platform size L	1.25m	1.25m
Platform size W	0.77m	0.77m
Platform size H	1.1m	1.1m
The length of platform extended	1.8m	1.8m
Skirting board height	0.17m	0.17m
Stowed size (LxW)	Metric system: 1.35m x 0.76m in : 3 ft 10 in x 2 ft 4 in	
Stowed height	1.5m	1.6m
Length of the machine with platform extended	1.8m	1.8m
Hydraulic tank capacity (L)	2	2
Gradeability	25%	25%
Wheelbase	1m	1m
Ground clearance	0.06m	0.06m
Inside rotation radius	0.35m	0.35m
Load number max	2	2
Raised time/Lowering time(s)	28/24	35/31
Travel speed	3km/h	3km/h
Safe speed	0.8km/h	0.8km/h
Vertical tilt*	2	2
Lateral tilt*	1	1
Power source	24V/95AH	24V/95AH
Tire size	Solid tire230m	Solid tire230m

*The metric system height is 2 meters higher than platform height, the imperial height is 6 feet than platform height

**CE/AU market, XE - MINI can be used in indoor and outdoor, to accommodate one person

***Climbing ability is suitable for driving on the slope, the slope classification reference operation manual

****Weight according to the options and standards vary from country to country

XE-MINI Working Range

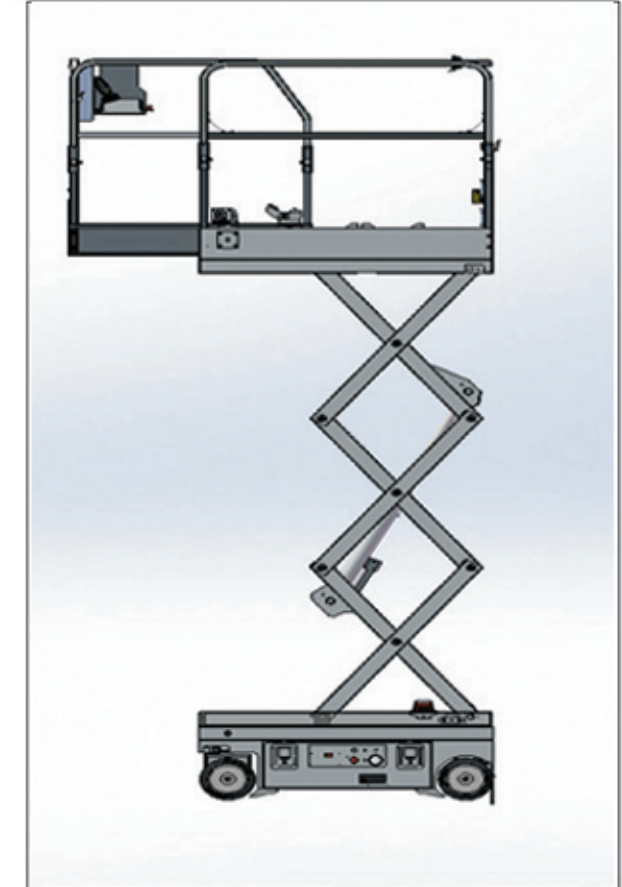

XE-MINI Collecting Chart

