

KOBELCO

S P E C I F I C A T I O N S

SK60
MARK III
HYDRAULIC EXCAVATOR



Features

Upper Machinery:

The Upper Machinery — Power and Intelligence

- Tough engine supplies plenty of power for continuous, trouble-free operation with a minimum of maintenance.
- Two mechatronic digging modes offer a wider range of power/speed combinations to suit the requirements of the job at hand.
- Computerized Intelligent Total Control System reliably coordinates the machine's advanced features for optimal economy and efficiency.
- FC mode cuts engine rpm and reduces maximum pump output for outstanding inching capability.
- Automatic engine deceleration quickly reduces engine speed to 1,050 rpm to minimize noise and fuel consumption while waiting for dump trucks.
- Easy-to-read multi-display monitor appraises all important machine functions and immediately warns the operator of possible machine failures before they develop into serious problems.

The Swing Circuit — Smooth and Secure

- Swing priority system ensures steady swing during operation of the arm, boom, bucket, and propel circuits.
- Automatic swing brake assures safe operation on slopes.
- Swing shockless valve gives smooth, exact swing stops with virtually no rebound motion.

The Cab — Quiet and Comfortable

- Luxurious, upholstered seat adjusts in six directions to keep the operator fresh and alert.
- Sleek, slant-nosed cab design with wide windows provides excellent visibility in all directions.
- Intermittent windshield wiper with double-spray washer maintains excellent visibility in bad weather.
- Cab rests on six rubber mounts strategically located to minimize vibration.
- Knit-fabric interior reduces in-cab noise and provides a relaxed, pleasant working environment.
- Sound-insulated engine compartment and other noise-reducing features provide a low on-site noise level.

- Compartment behind the seat provides convenient storage.
- Cab light can be operated automatically with the cab door or independently as needed.
- Safety lock on levers prevents accidental operation when entering and exiting cab.
- Magazine holder offers that little extra touch of luxury for spare moments on the job-site.
- One key fits the ignition and all other machine locks to simplify operation.
- Sun shade cuts down glare to reduce eye strain and improve visibility.
- Skylight with damper cylinders improves overhead visibility and ventilation.

Added Safety

- Rounded counterweight and tapered side decks reduce tail swing radius.
- One rearview mirror in the cab and two outside provide a clear view behind the machine.
- Swing flashers set in tough safety bumper flash automatically when the swing circuit is activated.
- Three powerful working lights in front and two at rear provide excellent illumination for nighttime work.

Attachment:**The Attachment —
Accuracy and Power**

- Sequenced arm recharge system increases hydraulic flow to the arm according to lever stroke for smooth control and powerful arm retraction.
- Boom and arm feature welded steel box sections.
- Four-point welded boom features high strength and light weight for maximum performance.

Easy Maintenance

- Grease gun holder keeps the grease gun neatly and conveniently stored within reach at all times.
- Centralized lubrication points for the swing bearing and attachments save time and effort.
- Easy-access remote lubrication of the arm tip simplifies routine maintenance requirement.

Lower Machinery:**The Lower Machinery —
Speed and Maneuverability**

- Maximum travel speed of 5.5 km/h in the High mode reduces travel time on the job site.
- Two-speed travel system automatically switches from high to low speed on hills or rough terrain where extra power is needed.
- High-pressure travel circuit maintains an outstanding drawbar pull of 5,200 kg even during combined attachment use.

**The Lower Structure —
Rugged and Durable**

- Lubricated and sealed long-pitch track links with strut reinforcement assure excellent durability.
- Slip-free steps on the crawler side frames provide sure footing during routine maintenance.
- All-welded, box-construction X-chassis provides strong and rigid support.
- Track tension is adjustable with a grease gun.

Technical Data



ENGINE

Model	ISUZU 4JB1, 4-cycle diesel
No. of cylinders	4
Bore and stroke	93 mm (3.66") x 102 mm (4.02")
Displacement	2,771 cc (169 cu in)
Rated power output	Net 57 PS (41.9 kW) at 2,200 rpm (ISO 9249/DIN 6271) Net 55 HP (40.7 kW) at 2,200 rpm (SAE J 1349)
Max. torque	Net 18 kg-m (176.5 N-m) at 1,800 rpm (ISO 9249/DIN6271)
Combustion system	Direct injection
Cooling system	Pressurized water circulated by a centrifugal pump
Lubrication system	Pressurized oil fed by a gear pump through full-flow spin-on filters
Starter	Electric, 24 V, 3.2 kW
Generator	20 A, 24 V
Air cleaner	Dry type with safety element
Batteries	2 x 12 V — (70 AH)



HYDRAULIC POWER SOURCE

Two pumps controlled by the KOBELCO Power Sensing System (KPSS), which senses where power is needed and automatically adjusts the pressure and flowrate to match the work loads. The KPSS reduces pumping losses and engine power demands to minimize fuel consumption. When the boom is hoisted or the arm extended, additional operation of the control lever doubles the hydraulic flow.

Pump	Two axial-piston, variable displacement pumps and one gear pump
Max. discharge flow	2 x 82 liters/min (2 x 18 UK gal/min)
Pilot oil flow	19.6 liters/min (4.3 UK gal/min)
Max. discharge pressure:	
Boom, arm and bucket	210 kg/cm ² (2,990 psi)
Propel circuit	260 kg/cm ² (3,700 psi)
Swing circuit	175 kg/cm ² (2,490 psi)
Control circuit	35 kg/cm ² (500 psi)
Oil filtration	One return filter with replacement element and a suction strainer
Pilot control pump	Gear type
Control valves	5-spool+1-spool
Oil cooler	Finned tube, forced ventilation
Pressure relief valves	Primary and secondary on each circuit



CONTROL AND CAB

The all-weather, die-formed, modular steel cab is mounted on six rubber pads and fitted with a heavy, insulated floor mat. Window area is large, all windows being in tinted, safety glass. The upper front window slides upwards in a single motion for storage under the cab roof and the lower front window is removable. The door and right-hand front window slide. The cloth covered, high-backed seat is fully adjustable, with convenient wrist-action controls that features one-touch tilt adjustment. Easy-to-read multi-display monitor checks all important machine functions and immediately warns the operator of possible machine failures before they develop into serious problems.

Pilot control	Boom, arm, bucket, swing and propel
Engine throttle	Electric, hand lever
Multi-display monitor:	
Indicators	Fuel meter, water temperature, hour meter
Lamps	Swing flasher, High and low travel, automatic engine deceleration
Lamps	Self-diagnostic display, (NG (no good) and OK), glow (pre-heating under way, pre-heating completed), engine oil pressure, pre-heating temperature, clogging of air cleaner filter, radiator water level, hydraulic oil level, battery charge, fuel level, CPU trouble, oil replacement, and time display
Standard cab fittings	Window washers, intermittent window wipers, fully adjustable reclining seat, cigarette lighter, ashtray, coat hook, floor mat, horn, cab light, and storage compartment
External lights:	
Front	One light mounted on the boom, one below the cab, and one under the battery case
Rear	One working light on each side of the counterweight plus swing flashers



SWING SYSTEM

The hydraulic, gear-driven swing is powered by an axial piston motor that is flange-connected to a planetary reduction unit driving the swing pinion. The single-row ball bearing unit has integral, internally cut swing gear and is totally enclosed to prevent the entry of mud and water.

Brake	Hydraulic, locking automatically when the swing control lever is in the neutral position
Parking brake	Hydraulic disc brake
Max. swing speed	13.0 rpm
Tail swing radius	1,700 mm (5' 7")
Min. front swing radius	1,700 mm (5' 7")



TRAVEL SYSTEM

The crawler tracks are fitted with interchangeable shoes and are supported by six lower rollers and one upper roller, with a guardplate on each side. Special track frame design with convenient cleaning holes simplifies mud removal. Spring-loaded track tensioning by the idler wheels protects the drives from shock, and is adjustable by grease cylinders. An all-welded undercarriage frame gives clog-free track clearance, and the drive motors are protected within the shoe width.

Drive motors	Independent, axial-piston, two-step motors for each side, driven through planetary speed reducers
Brakes	Independent, disc parking brakes for each side, applied automatically when the travel levers are in neutral
Track shoes	38 pads each side
Track tensioning	Hydraulic track adjusters and cushion springs
Lubrication	Lubricated rollers and front idlers with floating seals, lubricated and sealed track chains
Max. travel speed:	
High mode	5.5 km/h (3.4 mph)
Low mode	3.7 km/h (2.3 mph)
Drawbar pulling force	5,200 kg (11,460 lb)
Gradeability	70% (35°)
Ground clearance	380 mm (15")



BOOM, ARM AND BUCKET

The boom and arm feature pressed and welded steel box section. Buckets are fabricated from high tensile strength steel.

Boom cylinder	One, double-acting 125 mm (4.9") x 815 mm (2' 8") stroke
Arm cylinder	One, double-acting 110 mm (4.3") x 845 mm (2' 9") stroke
Bucket cylinder	One, double-acting 100 mm (3.9") x 695 mm (2' 3") stroke



REFILLING CAPACITIES AND LUBRICATION

Fuel tank	130 liters (29 UK gal)
Cooling system	10 liters (2.2 UK gal)
Engine oil	8 liters (1.8 UK gal)
Track drives	2 x 1.2 liters (2 x 0.3 UK gal)
Swing drive	4 liters (0.9 UK gal)
Hydraulic oil:	
Tank (oil level)	75 liters (16.5 UK gal)
Hydraulic system	112 liters (25 UK gal)
Lubrication:	
Swing system	Grease bath for gear, centralized greasing for bearing
Boom, arm, and attachments	Grease nipples, centralized greasing for remote points



WORKING RANGES

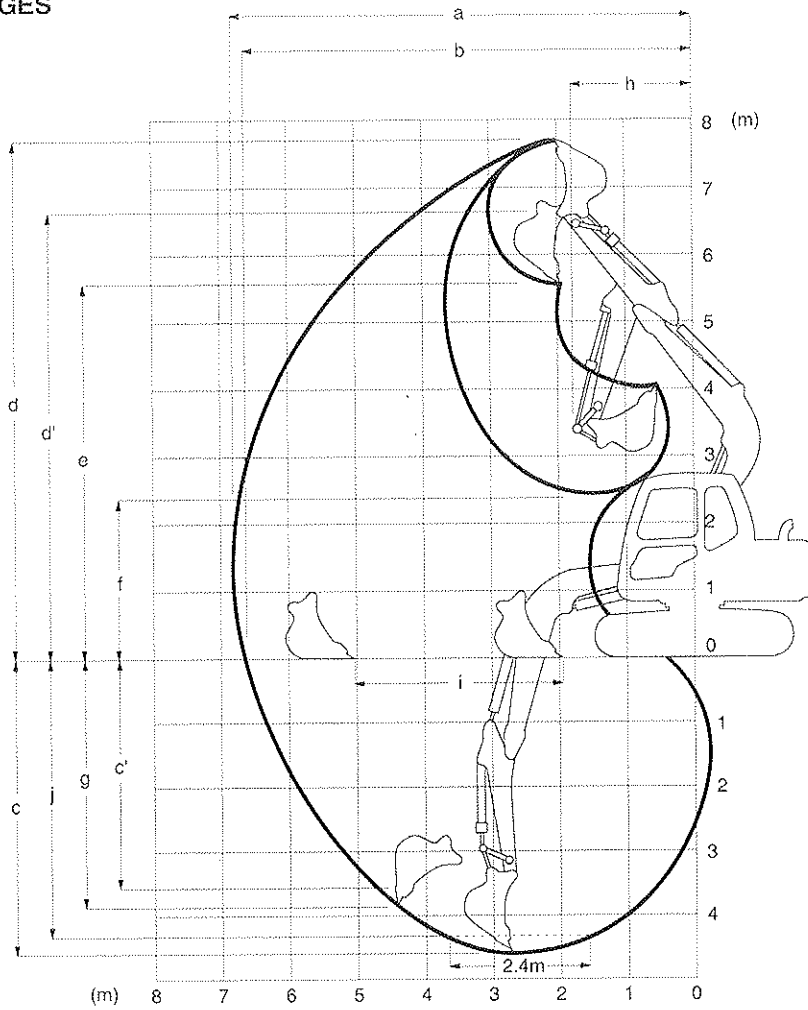

Unit: m (ft-in)

Range	Arm	Standard 1.73 (5 - 8)	2.15 (7 - 1)	1.73 (5 - 8) + 0.45 (1 - 6)
a — Max. digging reach		6.42 (21 - 1)	6.81 (22 - 4)	6.82 (22 - 5)
b — Max. digging reach at ground level		6.28 (20 - 7)	6.68 (21 - 11)	6.70 (22 - 0)
c — Max. digging depth		4.20 (13 - 9)	4.60 (15 - 1)	4.63 (15 - 2)
c' — Max. depth of bucket hinge pin		3.16 (10 - 4)	3.56 (11 - 8)	3.59 (11 - 9)
d — Max. digging height		7.36 (24 - 2)	7.69 (25 - 3)	7.68 (25 - 2)
d' — Max. height of bucket hinge pin		6.33 (20 - 9)	6.66 (21 - 10)	6.65 (21 - 10)
e — Max. dumping clearance		5.29 (17 - 4)	5.62 (18 - 5)	5.61 (18 - 5)
f — Min. dumping clearance		2.29 (7 - 6)	1.87 (6 - 2)	1.86 (6 - 1)
g — Max. vertical wall digging depth		3.47 (11 - 5)	3.85 (12 - 8)	3.78 (12 - 5)
h — Min. front swing radius		1.70 (5 - 7)	1.74 (5 - 9)	1.81 (5 - 11)
i — Horizontal digging stroke at ground level		2.92 (9 - 7)	3.63 (11 - 11)	3.61 (11 - 10)
j — Digging depth at 2.4 m (8') level bottom		3.85 (12 - 8)	4.33 (14 - 2)	4.37 (14 - 4)
Bucket capacity SAE/PCSA heaped	m ³ (cu yd)	0.25 (0.37)	0.20 (0.30)	0.20 (0.30)

* Without including height of shoe lugs.

Digging Force

Unit: kg (lb)

Arm length	m (ft-in)	1.73 (5 - 8)	2.15 (7 - 1)	1.73 (5 - 8)+0.45 (1 - 6)
Bucket digging force		4,800 (10,580)	4,800 (10,580)	4,800 (10,580)
Arm crowding force		3,700 (8,160)	3,200 (7,050)	3,200 (7,050)

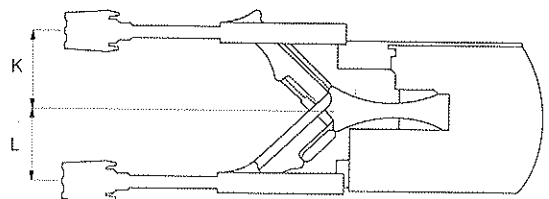
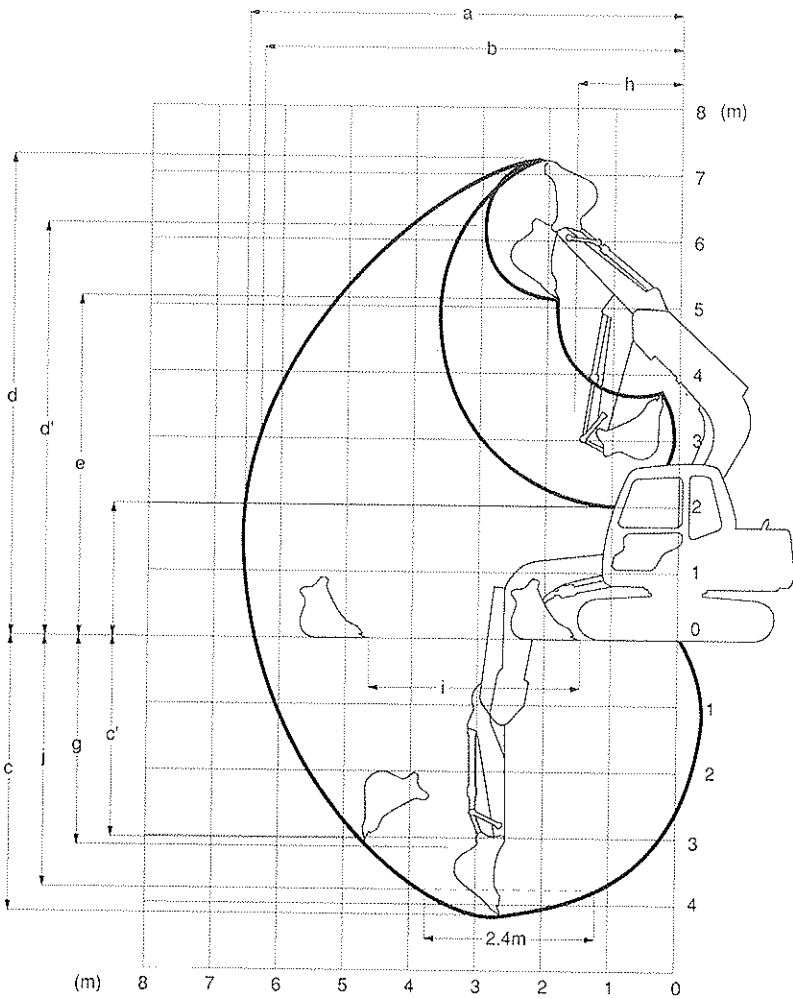

Unit: m (ft-in)

Range	Boom offset	Offset: Max.	Offset: 0
a — Max. digging reach		6.06 (19 - 11)	6.50 (21 - 4)
b — Max. digging reach at ground level		5.92 (19 - 5)	6.36 (20 - 10)
c — Max. digging depth		3.90 (12 - 10)	4.36 (14 - 4)
c' — Max. depth of bucket hinge pin		—	—
d — Max. digging height		6.99 (22 - 11)	7.33 (24 - 1)
d' — Max. height of bucket hinge pin		—	—
e — Max. dumping clearance		4.93 (16 - 2)	5.28 (17 - 4)
f — Min. dumping clearance		1.99 (6 - 6)	2.33 (7 - 8)
g — Max. vertical wall digging depth		2.84 (9 - 4)	3.28 (10 - 9)
h — Min. front swing radius		1.93 (6 - 4)	1.73 (5 - 8)
i — Horizontal digging stroke at ground level		—	—
j — Digging depth at 2.4 m (8') level bottom		—	—
k — Distance from center axis to offset boom position		1.13 (3 - 8)	0
l — Distance from center axis to offset boom position		1.13 (3 - 8)	0
Bucket capacity SAE/PCSA heaped	m ³ (cu yd)	0.1 - 0.2 (0.14 - 0.30)	



DIMENSIONS

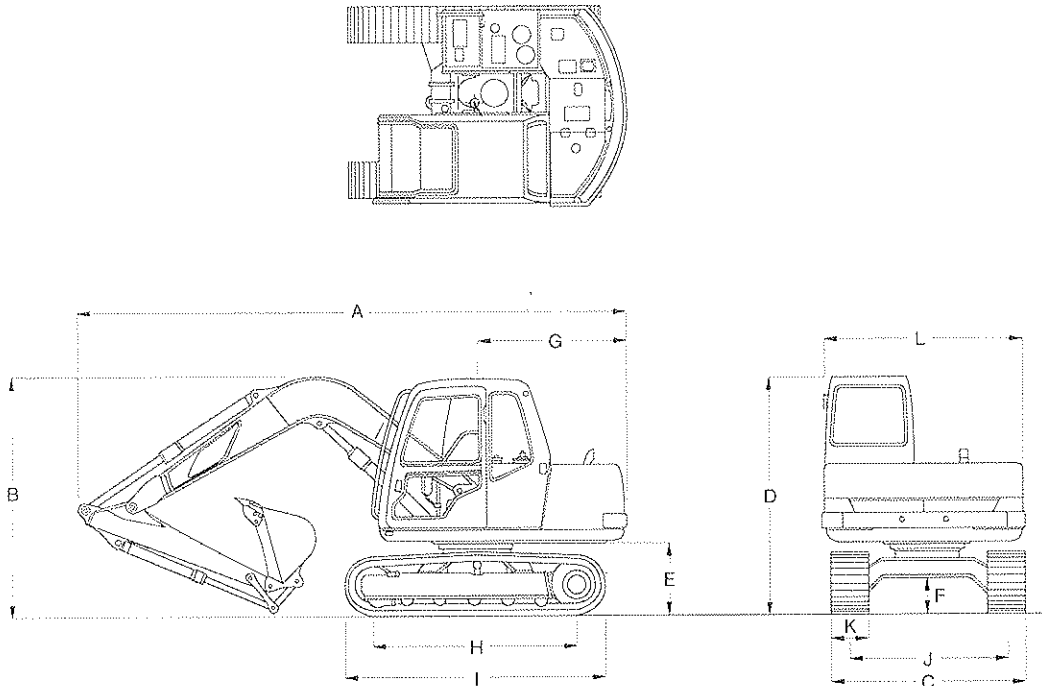

Dimensions

Unit:m (ft-in)

Dimensions		1.73m (5 - 8)	2.15m (7 - 1)	1.73m (5 - 8) + 0.45m (1 - 6)
A	Overall length	6.02 (19 - 9)	6.02 (19 - 9)	6.02 (19 - 9)
B	Overall height (to top of boom)	2.61 (8 - 7)	2.75 (9 - 0)	2.82 (9 - 3 3)
C	Overall width	2.10 (6 - 11)	2.10 (6 - 11)	2.10 (6 - 11)
D	Overall height (to top of cab)	2.60 (8 - 6)	2.60 (8 - 6)	2.60 (8 - 6)
E	Ground clearance of rear end*	0.77 (2 - 6)	0.77 (2 - 6)	0.77 (2 - 6)
F	Ground clearance*	0.38 (15")	0.38 (15")	0.38 (15")
G	Tail swing radius	1.70 (5 - 7)	1.70 (5 - 7)	1.70 (5 - 7)
H	Tumbler distance	2.16 (7 - 1)	2.16 (7 - 1)	2.16 (7 - 1)
I	Overall length of crawler	2.77 (9 - 1)	2.77 (9 - 1)	2.77 (9 - 1)
J	Track gauge	1.70 (5 - 7)	1.70 (5 - 7)	1.70 (5 - 7)
K	Shoe width	400mm (15.7")	400mm (15.7")	400mm (15.7")
L	Overall width of upperstructure	2.16 (7 - 1)	2.16 (7 - 1)	2.16 (7 - 1)

Note: Figure of asterisk (*) apply to value without shoe lug.



OPERATING WEIGHT AND GROUND PRESSURE

In standard trim, with 2.15m (7' 1") arm, and 0.20 m³ (0.30 cu yd) SAE/PCSA bucket.

		Triple grouser shoe		
Shape				
Shoe width	mm (in)	400 (15.7)	500 (19.7)	600 (23.6)
Overall width	mm (ft-in)	2,100 (6 - 11)	2,200 (7 - 3)	2,300 (7 - 7)
Ground pressure	kg/cm ² (psi)	0.34 (4.83)	0.27 (3.83)	0.23 (3.27)
Operating weight	kg (lb)	6,400 (14,100)	6,500 (14,300)	6,700 (14,800)



Backhoe bucket and arm combination

Uses	Bucket capacity m ³ (cu yd)			Opening width mm (in)		No. of teeth	Arm m (ft-in)		
	SAE/PCSA heaped	CECE heaped	Struck	With side cutters	Without side cutters		1.73(5-8)	2.15 (7-1)	1.73(5-8) + 0.45(1-6)
General purpose	0.11 (0.14)	0.1 (0.13)	0.09 (0.12)	— —	400 (15.7)	3	○	○	○
	0.18 (0.24)	0.16 (0.21)	0.14 (0.18)	560 (22.0)	490 (19.3)	3	○	○	○
	0.23 (0.30)	0.2 (0.26)	0.17 (0.22)	650 (25.6)	580 (22.8)	3	○	○	○
	0.28 (0.37)	0.25 (0.33)	0.22 (0.29)	770 (30.3)	700 (27.6)	4	○	△	△
	0.34 (0.44)	0.30 (0.39)	0.26 (0.34)	— —	820 (32.3)	4	△	×	×

○ Recommended △ Light material × Not recommended

Lifting Capacities

SK60 with 400mm shoe

LD: Boom point to hook point distance

Arm length (m)	Boom length 3.70m		Outreach in (m) — Loads in (kg)			
	Outreach (m)		3	4.5	6	7.5
1.73	LD=1.98	Z2	1,500	900	—	—
		Z1	1,700		—	—
		Z3	1,700		—	—
2.15	LD=2.39	Z2	1,300	900	—	—
		Z1	1,600		—	—
		Z3	1,700		—	—

SK60 with 500mm shoe

LD: Boom point to hook point distance

Arm length (m)	Boom length 3.70m		Outreach in (m) — Loads in (kg)			
	Outreach (m)		3	4.5	6	7.5
1.73	LD=1.98	Z2	1,500	900	—	—
		Z1	1,700		—	—
		Z3	1,800		—	—
2.15	LD=2.39	Z2	1,300	900	—	—
		Z1	1,600		—	—
		Z3	1,700		—	—

SK60 with 600mm shoe

LD: Boom point to hook point distance

Arm length (m)	Boom length 3.70m		Outreach in (m) — Loads in (kg)			
	Outreach (m)		3	4.5	6	7.5
1.73	LD=1.98	Z2	1,500	900	—	—
		Z1	1,700		—	—
		Z3	1,800		—	—
2.15	LD=2.39	Z2	1,300	900	—	—
		Z1	1,600		—	—
		Z3	1,800		—	—

Note: 1. These loads are valid for the height of the considered zone (Z.) for the intended outreach.
2. These loads show the value when each arm is equipped with the recommended bucket.

Working Conditions:

- With no tool (bucket, clamshell).
- With extended bucket cylinder.
- If object handling is performed with tool installed, the weight of the tool shall be deducted from the values of above table.
- On a compact horizontal level ground.
- In complete swing of the upperstructure.

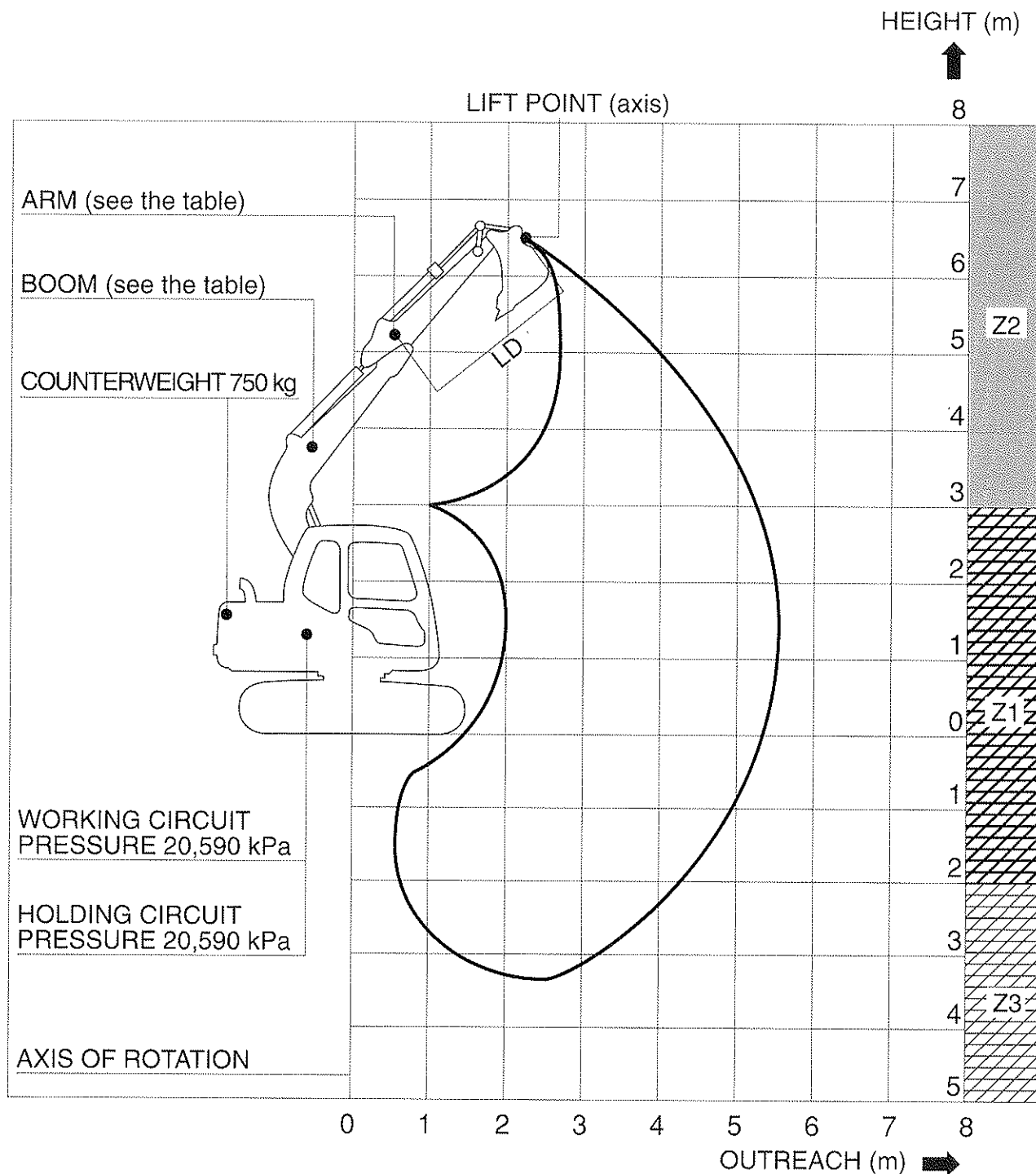

Notes:

1. Do not attempt to lift or hold any load that exceeds these rated values at their specified load radii and heights.
2. Lifting capacities assume a machine standing on a level, firm, and uniform supporting surface. Operator must make allowance for job conditions such as soft or uneven ground, out of level conditions, side loads, sudden stopping of loads, hazardous conditions, inexperienced personnel, weight

- of various other buckets, lifting slings, attachments, etc.
3. The rated loads are in compliance with CEN EN 474-5/ISO 10567 Rated Object Handling Capacity for crawler excavator. They do not exceed 87% of hydraulic lifting capacity or 75% of tipping load.
4. When a dozer blade is attached to SK60, SK110, SK130, and SK130LC, do not attempt to increase lifting ca-

- capacity by setting the blade on the ground and using it as a stability.
5. Operator should be fully acquainted with operator's manual before operating this machine. Rules for safe operation of equipment should be followed at all times.
6. Capacities apply only to the machine as originally manufactured and normally equipped by KOBE STEEL, LTD.

STANDARD EQUIPMENT

- Engine, ISUZU 4JB1
- Straight propel system
- Automatic shift two-speed travel
- One-push deceleration
- Sealed and lubricated track links
- Heavy duty batteries (2 x 12V-70 AH)
- Heavy duty batteries (2 x 12V-120 AH)*
- 24 volt to 12 volt converter
- Supply pump for fuel tank
- Starting motor (24V-3,2kW)
- Alternator (20 amp)
- Alternator (40 amp)*
- Single element air cleaner
- Removable clean out screen for radiator
- Remote pilot line junction block to facilitate easy control pattern change
- Tow eye
- Hydraulic oil cooler
- Horn, electric
- One interior rearview mirror and two outside rearview mirrors
- Three front and two rear working lights
- Swing flashers
- Extra lights*
- Hydraulic track adjusters
- Automatic swing brake
- 2 control levers, adjustable, pilot-operated
- Cab, all-weather sound suppressed type with ashtray, cigarette lighter, cab light (interior), coat hook, floor mat, 6-way adjustable suspension seat, cloth and cushion, seat belt, head rest, hand rails, heater with defroster, intermittent windshield wiper with double-spray washer, skylight, sun shade, tinted safety glass, pull type front window and removable lower front window
- Instrument panel: Easy-to-read multi display monitor
- Swing shockless valve
- Sequenced arm recharge system
- 1.73 m standard arm
- 400 mm triple grouser track shoes (38 pads each side)
- Noise level certificate
- Engine oil quick and clean drain cock

* Scandinavian specifications

OPTIONAL EQUIPMENT

- Radio, AM/FM Stereo with speakers
- Wide range of buckets
- Various optional arms
- Quick coupler
- Various hydraulic systems for attachments
- Seat belt
- Safety holding valves for arm and boom cylinders
- Front guard protective structures
- Top guard protective structures
- Dozer complete (factory installation)
- Dozer complete, tilt and breaker piping (factory installation)
- Dozer complete and tilt piping (factory installation)
- Dozer (blade less) preparation (factory installation)
- Dozer (blade less) preparation, tilt and breaker piping (factory installation)
- Dozer (blade less) preparation, tilt piping (factory installation)



Note: This catalogue may contain attachments and optional equipment that are not available in your area. Please consult your nearest KOBELCO distributor for those items you may require. Due to our policy of continual product improvements all designs and specifications are subject to change without advance notice.

 **KOBE STEEL, LTD.**

ENGINEERING & MACHINERY DIVISION

Construction Machinery & Compressor Group

Kobelco Bldg., 3-2, Toyo 2-chome Koto-ku, TOKYO, 135 Japan

Tel: (03) 5634-5311 Fax: (03) 5634-5533

Kobelco Construction Machinery (EUROPE) B.V.

Bolderweg 50, 1332 AW Almere (De Vaart), The Netherlands

Tel: (31) 36-5329475 Fax: (31) 36-5329435

Bulletin No. SK60-III-EC-101-E

Inquiries to:



Otto Wohlgenannt Ges.m.b.H.
Fahrzeugbau und LKW - Kräne
WOHLGENANN
 A- 6853 Dornbirn, Wallenmahd 63
 Tel. 05572 / 22073 FAX 05572 / 20055
 Aus dem Ausland: 0043 / 5572 / 22073

Printed in The Netherlands